



OPEN

Industry Standard, Flexible Architecture

GREEN

Less Heat, Less Power Consumption

STABLE

Robust Design, Quality Parts

Stable and
Reliable Solution

Server/Workstation

Motherboard

E3C256D4U-2L2T

E3C252D4U-2T

E3C252D4U

E3C256D4U-2L2T/BCM

E3C252D4U-2T/BCM

E3C256D4U-2L2T/X550

User Manual

English

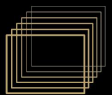

Version 1.0

Published December 2022

Copyright©2022 ASRock Rack INC. All rights reserved.

Copyright Notice:

No part of this documentation may be reproduced, transcribed, transmitted, or translated in any language, in any form or by any means, except duplication of documentation by the purchaser for backup purpose, without written consent of ASRock Rack Inc.

Products and corporate names appearing in this documentation may or may not be registered trademarks or copyrights of their respective companies, and are used only for identification or explanation and to the owners' benefit, without intent to infringe.

Disclaimer:

Specifications and information contained in this documentation are furnished for informational use only and subject to change without notice, and should not be constructed as a commitment by ASRock Rack. ASRock Rack assumes no responsibility for any errors or omissions that may appear in this documentation.

With respect to the contents of this documentation, ASRock Rack does not provide warranty of any kind, either expressed or implied, including but not limited to the implied warranties or conditions of merchantability or fitness for a particular purpose.

In no event shall ASRock Rack, its directors, officers, employees, or agents be liable for any indirect, special, incidental, or consequential damages (including damages for loss of profits, loss of business, loss of data, interruption of business and the like), even if ASRock Rack has been advised of the possibility of such damages arising from any defect or error in the documentation or product.



This device complies with Part 15 of the FCC Rules. Operation is subject to the following two conditions:

- (1) this device may not cause harmful interference, and
- (2) this device must accept any interference received, including interference that may cause undesired operation.

This equipment has been tested and found to comply with the limits for a Class B digital device, pursuant to part 15 of the FCC Rules. These limits are designed to provide reasonable protection against harmful interference in a residential installation. This equipment generates, uses and can radiate radio frequency energy and, if not installed and used in accordance with the instructions, may cause harmful interference to radio communications. However, there is no guarantee that interference will not occur in a particular installation. If this equipment does cause harmful interference to radio or television reception, which can be determined by turning the equipment off and on, the user is encouraged to try to correct the interference by one or more of the following measures:

- Reorient or relocate the receiving antenna.
- Increase the separation between the equipment and receiver.

- Connect the equipment into an outlet on a circuit different from that to which the receiver is connected.
- Consult the dealer or an experienced radio/TV technician for help.

The terms HDMI® and HDMI High-Definition Multimedia Interface, and the HDMI logo are trademarks or registered trademarks of HDMI Licensing LLC in the United States and other countries.



**INTEL END USER SOFTWARE LICENSE AGREEMENT
IMPORTANT - READ BEFORE COPYING, INSTALLING OR USING.**

LICENSE. Licensee has a license under Intel's copyrights to reproduce Intel's Software only in its unmodified and binary form, (with the accompanying documentation, the "Software") for Licensee's personal use only, and not commercial use, in connection with Intel-based products for which the Software has been provided, subject to the following conditions:

- (a) Licensee may not disclose, distribute or transfer any part of the Software, and You agree to prevent unauthorized copying of the Software.
- (b) Licensee may not reverse engineer, decompile, or disassemble the Software.
- (c) Licensee may not sublicense the Software.
- (d) The Software may contain the software and other intellectual property of third party suppliers, some of which may be identified in, and licensed in accordance with, an enclosed license.txt file or other text or file.
- (e) Intel has no obligation to provide any support, technical assistance or updates for the Software.

OWNERSHIP OF SOFTWARE AND COPYRIGHTS. Title to all copies of the Software remains with Intel or its licensors or suppliers. The Software is copyrighted and protected by the laws of the United States and other countries, and international treaty provisions. Licensee may not remove any copyright notices from the Software. Except as otherwise expressly provided above, Intel grants no express or implied right under Intel patents, copyrights, trademarks, or other intellectual property rights. Transfer of the license terminates Licensee's right to use the Software.

DISCLAIMER OF WARRANTY. The Software is provided "AS IS" without warranty of any kind, EITHER EXPRESS OR IMPLIED, INCLUDING WITHOUT LIMITATION, WARRANTIES OF MERCHANTABILITY OR FITNESS FOR ANY PARTICULAR PURPOSE.

LIMITATION OF LIABILITY. NEITHER INTEL NOR ITS LICENSORS OR SUPPLIERS WILL BE LIABLE FOR ANY LOSS OF PROFITS, LOSS OF USE, INTERRUPTION OF BUSINESS, OR INDIRECT, SPECIAL, INCIDENTAL, OR CONSEQUENTIAL DAMAGES OF ANY KIND WHETHER UNDER THIS AGREEMENT OR OTHERWISE, EVEN IF INTEL HAS BEEN ADVISED OF THE POSSIBILITY OF SUCH DAMAGES.

LICENSE TO USE COMMENTS AND SUGGESTIONS. This Agreement does NOT obligate Licensee to provide Intel with comments or suggestions regarding the Software. However, if Licensee provides Intel with comments or suggestions for the modification,

correction, improvement or enhancement of (a) the Software or (b) Intel products or processes that work with the Software, Licensee grants to Intel a non-exclusive, worldwide, perpetual, irrevocable, transferable, royalty-free license, with the right to sublicense, under Licensee's intellectual property rights, to incorporate or otherwise utilize those comments and suggestions.

TERMINATION OF THIS LICENSE. Intel or the sublicensor may terminate this license at any time if Licensee is in breach of any of its terms or conditions. Upon termination, Licensee will immediately destroy or return to Intel all copies of the Software.

THIRD PARTY BENEFICIARY. Intel is an intended beneficiary of the End User License Agreement and has the right to enforce all of its terms.

U.S. GOVERNMENT RESTRICTED RIGHTS. The Software is a commercial item (as defined in 48 C.F.R. 2.101) consisting of commercial computer software and commercial computer software documentation (as those terms are used in 48 C.F.R. 12.212), consistent with 48 C.F.R. 12.212 and 48 C.F.R. 227.7202-1 through 227.7202-4. You will not provide the Software to the U.S. Government. Contractor or Manufacturer is Intel Corporation, 2200 Mission College Blvd., Santa Clara, CA 95054.

EXPORT LAWS. Licensee agrees that neither Licensee nor Licensee's subsidiaries will export/re-export the Software, directly or indirectly, to any country for which the U.S. Department of Commerce or any other agency or department of the U.S. Government or the foreign government from where it is shipping requires an export license, or other governmental approval, without first obtaining any such required license or approval. In the event the Software is exported from the U.S.A. or re-exported from a foreign destination by Licensee, Licensee will ensure that the distribution and export/re-export or import of the Software complies with all laws, regulations, orders, or other restrictions of the U.S. Export Administration Regulations and the appropriate foreign government.

APPLICABLE LAWS. This Agreement and any dispute arising out of or relating to it will be governed by the laws of the U.S.A. and Delaware, without regard to conflict of laws principles. The Parties to this Agreement exclude the application of the United Nations Convention on Contracts for the International Sale of Goods (1980). The state and federal courts sitting in Delaware, U.S.A. will have exclusive jurisdiction over any dispute arising out of or relating to this Agreement. The Parties consent to personal jurisdiction and venue in those courts. A Party that obtains a judgment against the other Party in the courts identified in this section may enforce that judgment in any court that has jurisdiction over the Parties.

Licensee's specific rights may vary from country to country.

CALIFORNIA, USA ONLY

The Lithium battery adopted on this motherboard contains Perchlorate, a toxic substance controlled in Perchlorate Best Management Practices (BMP) regulations passed by the California Legislature. When you discard the Lithium battery in California, USA, please follow the related regulations in advance.

“Perchlorate Material-special handling may apply, see www.dtsc.ca.gov/hazardouswaste/perchlorate”

AUSTRALIA ONLY

Our goods come with guarantees that cannot be excluded under the Australian Consumer Law. You are entitled to a replacement or refund for a major failure and compensation for any other reasonably foreseeable loss or damage caused by our goods. You are also entitled to have the goods repaired or replaced if the goods fail to be of acceptable quality and the failure does not amount to a major failure. If you require assistance please call ASRock Rack Tel : +886-2-55599600 ext.123 (Standard International call charges apply)



ASRock Rack INC. hereby declares that this device is in compliance with the essential requirements and other relevant provisions of related UKCA Directives. Full text of UKCA declaration of conformity is available at: <http://www.asrockrack.com>



ASRock Rack INC. hereby declares that this device is in compliance with the essential requirements and other relevant provisions of related Directives. Full text of EU declaration of conformity is available at: <http://www.asrockrack.com>

ASRock Rack follows the green design concept to design and manufacture our products, and makes sure that each stage of the product life cycle of ASRock Rack product is in line with global environmental regulations. In addition, ASRock Rack disclose the relevant information based on regulation requirements.

Please refer to <https://www.asrockrack.com/general/about.asp?cat=Responsibility> for information disclosure based on regulation requirements ASRock Rack is complied with:



DO NOT throw the motherboard in municipal waste. This product has been designed to enable proper reuse of parts and recycling. This symbol of the crossed out wheeled bin indicates that the product (electrical and electronic equipment) should not be placed in municipal waste. Check local regulations for disposal of electronic products.

Contents

| | |
|---|-----------|
| Chapter 1 Introduction | 1 |
| 1.1 Package Contents | 1 |
| 1.2 Specifications | 2 |
| 1.3 Unique Features | 10 |
| 1.4 Motherboard Layout | 11 |
| 1.5 Onboard LED Indicators | 17 |
| 1.6 I/O Panel | 19 |
| 1.7 Block Diagram | 23 |
| Chapter 2 Installation | 24 |
| 2.1 Screw Holes | 24 |
| 2.2 Pre-installation Precautions | 24 |
| 2.3 Installing the CPU | 25 |
| 2.4 Installing the CPU Fan and Heatsink | 27 |
| 2.5 Installation of Memory Modules (DIMM) | 28 |
| 2.6 Expansion Slots (PCI Express Slots) | 30 |
| 2.7 Jumper Setup | 31 |
| 2.8 Onboard Headers and Connectors | 32 |
| 2.9 Dr. Debug | 38 |
| 2.10 Unit Identification purpose LED/Switch | 44 |
| 2.11 Dual LAN and Teaming Operation Guide | 45 |
| 2.12 M.2 SSD Module Installation Guide (M2_1) | 46 |
| 2.13 M.2 SSD Module Installation Guide (M2_2) | 48 |

| | |
|---------------------------------------|-----------|
| Chapter 3 UEFI Setup Utility | 50 |
| 3.1 Introduction | 50 |
| 3.1.1 UEFI Menu Bar | 50 |
| 3.1.2 Navigation Keys | 51 |
| 3.2 Main Screen | 52 |
| 3.3 Advanced Screen | 53 |
| 3.3.1 CPU Configuration | 54 |
| 3.3.2 DRAM Configuration | 57 |
| 3.3.3 Chipset Configuration | 58 |
| 3.3.4 Storage Configuration | 60 |
| 3.3.5 NVMe Configuration | 61 |
| 3.3.6 ACPI Configuration | 62 |
| 3.3.7 Super IO Configuration | 63 |
| 3.3.8 Serial Port Console Redirection | 64 |
| 3.3.9 H/W Monitor | 67 |
| 3.3.10 Intel SPS Configuration | 68 |
| 3.3.11 Driver Health | 69 |
| 3.3.12 Tls Auth Configuration | 71 |
| 3.3.13 RAM Disk Configuration | 72 |
| 3.3.14 iSCSI Configuration | 73 |
| 3.3.15 Instant Flash | 74 |
| 3.4 Server Mgmt | 75 |
| 3.4.1 BMC Network Configuration | 76 |
| 3.4.2 System Event Log | 78 |

| | | |
|-----------------------------------|-----------------------------------|-----------|
| 3.4.3 | Bmc self test log | 79 |
| 3.4.4 | BMC Tools | 80 |
| 3.5 | Security | 81 |
| 3.5.1 | Key Management | 82 |
| 3.6 | Boot Screen | 86 |
| 3.7 | Event Logs | 88 |
| 3.8 | Exit Screen | 89 |
| Chapter 4 Software Support | | 90 |
| 4.1 | Install Operating System | 90 |
| 4.2 | Support CD Information | 90 |
| 4.2.1 | Running The Support CD | 90 |
| 4.2.2 | Drivers Menu | 90 |
| 4.2.3 | Utilities Menu | 90 |
| 4.2.4 | Contact Information | 90 |
| Chapter 5 Troubleshooting | | 91 |
| 5.1 | Troubleshooting Procedures | 91 |
| 5.2 | Technical Support Procedures | 93 |
| 5.3 | Returning Merchandise for Service | 93 |

Chapter 1 Introduction

Thank you for purchasing ASRock Rack **E3C256D4U-2L2T / E3C252D4U-2T / E3C252D4U / E3C256D4U-2L2T/BCM / E3C252D4U-2T/BCM / E3C256D4U-2L2T/X550** motherboard, a reliable motherboard produced under ASRock Rack's consistently stringent quality control. It delivers excellent performance with robust design conforming to ASRock Rack's commitment to quality and endurance.

In this manual, chapter 1 and 2 contains introduction of the motherboard and step-by-step guide to the hardware installation. Chapter 3 and 4 contains the configuration guide to BIOS setup and information of the Support CD.



Because the motherboard specifications and the BIOS software might be updated, the content of this manual will be subject to change without notice. In case any modifications of this manual occur, the updated version will be available on ASRock Rack website without further notice. You may find the latest memory and CPU support lists on ASRock Rack website as well. ASRock Rack's Website: www.ASRockRack.com

*If you require technical support related to this motherboard, please visit our website for specific information about the model you are using.
<http://www.asrockrack.com/support/>*

1.1 Package Contents

- ASRock Rack Motherboard:
E3C256D4U-2L2T
E3C252D4U-2T
E3C252D4U
E3C256D4U-2L2T/BCM
E3C252D4U-2T/BCM
E3C256D4U-2L2T/X550
(mATX Form Factor: 9.6-in x 9.6-in, 24.4 cm x 24.4 cm)
- Quick Installation Guide
- 1 x SATA3 Cable (60cm)
- 1 x I/O Shield
- 2 x Screws for M.2 Sockets
(for E3C256D4U-2L2T / E3C256D4U-2L2T/BCM / E3C256D4U-2L2T/X550 only)
- 1 x Screw for M.2 Socket
(for E3C252D4U-2T / E3C252D4U / E3C252D4U-2T/BCM only)



If any items are missing or appear damaged, contact your authorized dealer.

1.2 Specifications

| E3C256D4U-2L2T E3C256D4U-2L2T/BCM E3C256D4U-2L2T/X550 | |
|---|--|
| Physical Status | |
| Form Factor | Micro-ATX |
| Dimension (W*D) | 9.6" x 9.6" (244 mm x 244 mm) |
| Processor System | |
| Supported CPU | Support Intel® Rocket Lake-E and Pentium Series Processors |
| Socket | LGA 1200 |
| Max. Thermal Design Power (TDP) | 95W |
| Chipset | Intel® C256 |
| System Memory | |
| Memory channels | 2 |
| Supported DIMM Q'ty | 4 (2DPC) |
| Supported Type | DDR4 288-pin ECC/non-ECC UDIMM |
| Max. Frequency | 3200 MHz |
| Max. Capacity per DIMM | 32GB |
| Voltage | 1.2V |
| Note | -Up to DDR4 2666 MHz when installing Pentium Series Processors |
| PCIe Expansion Slots (Slot7 close to CPU) | |
| Slot 7 | E3C256D4U-2L2T: PCIe 3.0 x1 [PCH] E3C256D4U-2L2T/BCM: N/A E3C256D4U-2L2T/X550: PCIe 3.0 x1 [PCH] |
| Slot 6 | Latch PCIe x16 (PCIe 4.0 x16) [CPU] |
| Slot 4 | Open-end PCIe x4 (PCIe 4.0 x4) [CPU] |
| Note | -SLOT6 supports PCIe3.0 only and SLOT4 will not function when installing Pentium Series Processors |
| Other PCIe Expansion Connectors | |
| M.2 | 1 M-key (PCIe3.0 x4 or SATA 6Gb/s); support 22110/2280/2260 form factor 1 M-key (PCIe3.0 x4); support 2280/2260 form factor |
| Note | -M2_1 SATA interface is shared with SATA0 by BIOS setting |
| SATA/SAS Storage | |
| PCH Built-in Storage | Intel® C256 (8 SATA 6Gb/s; RAID 0/1/5/10): 7 SATA 7-pin, 1 support SATA DOM or M.2 |

| | |
|--|--|
| Networking | |
| Additional Ethernet Controller | E3C256D4U-2L2T: Intel®X710-AT2: 2 RJ45 (10GbE) Intel®i210: 2 RJ45 (1GbE) E3C256D4U-2L2T/BCM: Broadcom 57416: 2 RJ45 (10GbE) Intel®i210: 2 RJ45 (1GbE) E3C256D4U-2L2T/X550: Intel®X550-AT2: 2 RJ45 (10GbE) Intel®i210: 2 RJ45 (1GbE) |
| USB | |
| Controller/ Hub | Intel® C256 |
| Connectors/ headers | Rear IO: 4 Type A (USB3.2 Gen1) Internal: 2 via 19-pin header (USB3.2 Gen1) 2 via 9-pin header (USB2.0)" |
| Graphics | |
| Controller | ASPEED AST2500: 1 DB15 (VGA), 1 (15-pin) header Intel® Integrated Processor Graphics: 1 HDMI |
| Security | |
| TPM | 1 (13-pin, SPI) |
| Rear I/O | |
| UID | 1 button w/ LED |
| Video output | 1 DB15 (VGA), 1 HDMI |
| Serial port | 1 DB9 |
| USB | 4 Type A (USB3.2 Gen1 5Gbps) |
| RJ45 | 2 (10GbE), 2 (1GbE), 1 dedicated IPMI |
| System Monitoring | |
| Temperature | CPU, MB, Card side, TR1 |
| Fan | Fan Tachomete, CPU Quiet Fan (Allow Chassis Fan Speed Auto-Adjust by CPU Temperature), Multi-Speed Control |
| Voltage | +12V, +5V, +3.3V, CPU Vcore, DRAM,V1.0M,+BAT, 3VSB, 5VSB |
| BIOS | |
| BIOS type | AMI UEFI BIOS; 256 Mb (32MB) SPI Flash ROM |
| Features | Plug and Play, ACPI 3.0 compliance wake up events, SMBIOS 3.2, ASRock Rack instant flash |
| Other Internal headers, LEDs, jumpers | |
| ATX PSU connector | 1 (24-pin, ATX main power), 1 (8-pin, ATX 12V) |
| Auxiliary panel header | 1 (18-pin): chassis intrusion, system fault LED, LAN1/LAN2 activity LED, locate, SMBus |

| | |
|-----------------------------|--|
| System panel header | 1 (9-pin): power switch, reset switch, system power LED, HDD activity LED |
| LAN3/LAN4 LED header | 1 |
| SGPIO | 1 |
| VGA header | 1 |
| Speaker header | 1 |
| NMI button | 1 |
| Fan header | 7 (4-pin) |
| Thermal sensor header | 1 |
| Buzzer | 1 |
| TPM/Port 80 header | 1 (13-pin, SPI) |
| IPMB header | 1 |
| SMbus | 1 |
| PMbus | 1 |
| Clear CMOS | 1 (contact pads) |
| ME/SPS recovery | 1 |
| Type-A USB 2.0 | E3C256D4U-2L2T: N/A E3C256D4U-2L2T/BCM: N/A E3C256D4U-2L2T/X550: 1 |
| LED Indicators | |
| BMC Heartbeat LED | 1 |
| StandbyPower LED | 1 |
| FanFail LED | 7 |
| 80 debug port LED (2 digit) | 1 |
| Support OS | |
| OS | Microsoft® Windows® - Server 2019 (64 bit) - Server 2022 (64 bit) Linux® - SUSE Enterprise Linux Server 15 SP2 (64 bit) - Ubuntu 21.04 (64 bit) Hypervisor: - VMWare® ESXi 7.0U2a / vSphere 7.0U2b <i>*Supports UEFI BOOT only.</i> <i>*Please refer to our website for the latest OS support list.</i> |

Environment

| | |
|---------------------------|--------------------------|
| Operating temperature | 10 - 35°C (50 - 95°F) |
| Non-operating temperature | -40 - 70°C (-40 - 158°F) |



This motherboard supports Wake from on Board LAN. To use this function, please make sure that the "Wake on Magic Packet from power off state" is enabled in Device Manager > Intel® Ethernet Connection > Power Management. And the "PCI Devices Power On" is enabled in UEFI SETUP UTILITY > Advanced > ACPI Configuration. After that, onboard LAN1&2 can wake up S5 under OS.



If you install Intel® LAN utility or Marvell SATA utility, this motherboard may fail Windows® Hardware Quality Lab (WHQL) certification tests. If you install the drivers only, it will pass the WHQL tests.

E3C252D4U-2T**E3C252D4U-2T/BCM****E3C252D4U****Physical Status**

| | |
|-----------------|-------------------------------|
| Form Factor | Micro-ATX |
| Dimension (W*D) | 9.6" x 9.6" (244 mm x 244 mm) |

Processor System

| | |
|---------------------------------|--|
| Supported CPU | Support Intel® Rocket Lake-E and Pentium Series Processors |
| Socket | LGA 1200 |
| Max. Thermal Design Power (TDP) | 95W |
| Chipset | Intel® C252 |

System Memory

| | |
|------------------------|--|
| Memory channels | 2 |
| Supported DIMM Q'ty | 4 (2DPC) |
| Supported Type | DDR4 288-pin ECC/non-ECC UDIMM |
| Max. Frequency | 3200 MHz |
| Max. Capacity per DIMM | 32GB |
| Voltage | 1.2V |
| Note | -Up to DDR4 2666 MHz when installing Pentium Series Processors |

PCIe Expansion Slots (Slot7 close to CPU)

| | |
|--------|--|
| Slot 7 | E3C252D4U-2T: PCIe 3.0 x1 [PCH] E3C252D4U-2T/BCM: N/A E3C252D4U: PCIe 3.0 x1 [PCH] |
| Slot 6 | Latch PCIe x16 (PCIe 4.0 x16) [CPU] |
| Slot 4 | Open-end PCIe x4 (PCIe 4.0 x4) [CPU] |
| Note | -SLOT6 supports PCIe3.0 only and SLOT4 will not function when installing Pentium Series Processors |

Other PCIe Expansion Connectors

| | |
|------|---|
| M.2 | 1 M-key (PCIe3.0 x2 or SATA 6Gb/s); support 22110/2280/2260 form factor |
| Note | -M2_1 SATA interface is shared with SATA0 by BIOS setting |

SATA/SAS Storage

| | |
|----------------------|--|
| PCH Built-in Storage | Intel® C252 (6 SATA 6Gb/s; RAID 0/1/5/10): 5 SATA 7-pin, 1 support SATA DOM or M.2" |
|----------------------|--|

| Networking | |
|---------------------------------------|--|
| Additional Ethernet Controller | E3C252D4U-2T: Intel®X710-AT2: 2 RJ45 (10GbE) E3C252D4U-2T/BCM: Broadcom 57416: 2 RJ45 (10GbE) E3C252D4U: Intel®i210: 2 RJ45 (1GbE) |
| USB | |
| Controller/ Hub | Intel® C252 |
| Connectors/ headers | Rear IO: 4 Type A (USB3.2 Gen1) Internal: 2 via 19-pin header (USB3.2 Gen1) 2 via 9-pin header (USB2.0)" |
| Graphics | |
| Controller | ASPEED AST2500: 1 DB15 (VGA), 1 (15-pin) header Intel® Integrated Processor Graphics: 1 HDMI |
| Security | |
| TPM | 1 (13-pin, SPI) |
| Rear I/O | |
| UID | 1 button w/ LED |
| Video output | 1 DB15 (VGA), 1 HDMI |
| Serial port | 1 DB9 |
| USB | 4 Type A (USB3.2 Gen1 5Gbps) |
| RJ45 | 2 (10GbE), 2 (1GbE), 1 dedicated IPMI |
| System Monitoring | |
| Temperature | CPU, MB, Card side, TR1 |
| Fan | Fan Tachomete, CPU Quiet Fan (Allow Chassis Fan Speed Auto-Adjust by CPU Temperature), Multi-Speed Control |
| Voltage | +12V, +5V, +3.3V, CPU Vcore, DRAM,V1.0M,+BAT, 3VSB, 5VSB |
| BIOS | |
| BIOS type | AMI UEFI BIOS; 256 Mb (32MB) SPI Flash ROM |
| Features | Plug and Play, ACPI 3.0 compliance wake up events, SMBIOS 3.2, ASRock Rack instant flash |
| Other Internal headers, LEDs, jumpers | |
| ATX PSU connector | 1 (24-pin, ATX main power), 1 (8-pin, ATX 12V) |
| Auxiliary panel header | 1 (18-pin): chassis intrusion, system fault LED, LAN1/LAN2 activity LED, locate, SMBus |
| System panel header | 1 (9-pin): power switch, reset switch, system power LED, HDD activity LED |

| | |
|-----------------------------|--|
| LAN3/LAN4 LED header | 1 |
| SGPIO | 1 |
| VGA header | 1 |
| Speaker header | 1 |
| NMI button | 1 |
| Fan header | 7 (4-pin) |
| Thermal sensor header | 1 |
| Buzzer | 1 |
| TPM/Port 80 header | 1 (13-pin, SPI) |
| IPMB header | 1 |
| SMbus | 1 |
| PMbus | 1 |
| Clear CMOS | 1 (contact pads) |
| ME/SPS recovery | 1 |
| LED Indicators | |
| BMC Heartbeat LED | 1 |
| StandbyPower LED | 1 |
| FanFail LED | 7 |
| 80 debug port LED (2 digit) | 1 |
| Support OS | |
| OS | <p>Microsoft® Windows*</p> <ul style="list-style-type: none"> - Server 2019 (64 bit) - Server 2022 (64 bit) <p>Linux*</p> <ul style="list-style-type: none"> - SUSE Enterprise Linux Server 15 SP2 (64 bit) - Ubuntu 21.04 (64 bit) <p>Hypervisor:</p> <ul style="list-style-type: none"> - VMWare® ESXi 7.0U2a / vSphere 7.0U2b <p><i>*Supports UEFI BOOT only.</i></p> <p><i>*Please refer to our website for the latest OS support list.</i></p> |
| Enviroment | |
| Operating temperature | 10 - 35°C (50 - 95°F) |
| Non-operating temperature | -40 - 70°C (-40 - 158°F) |



This motherboard supports Wake from on Board LAN. To use this function, please make sure that the "Wake on Magic Packet from power off state" is enabled in Device Manager > Intel® Ethernet Connection > Power Management. And the "PCI Devices Power On" is enabled in UEFI SETUP UTILITY > Advanced > ACPI Configuration. After that, onboard LAN1&2 can wake up S5 under OS.



If you install Intel® LAN utility or Marvell SATA utility, this motherboard may fail Windows® Hardware Quality Lab (WHQL) certification tests. If you install the drivers only, it will pass the WHQL tests.

1.3 Unique Features

ASRock Rack Instant Flash is a BIOS flash utility embedded in Flash ROM. This convenient BIOS update tool allows you to update system BIOS without entering operating systems first like MS-DOS or Windows. With this utility, you can press the <F6> key during the POST or the <F2> key to enter into the BIOS setup menu to access ASRock Rack Instant Flash. Just launch this tool and save the new BIOS file to your USB flash drive, floppy disk or hard drive, then you can update your BIOS only in a few clicks without preparing an additional floppy diskette or other complicated flash utility. Please be noted that the USB flash drive or hard drive must use FAT32/16/12 file system.

1.4 Motherboard Layout

E3C256D4U-2L2T
 E3C256D4U-2L2T/BCM
 E3C256D4U-2L2T/X550

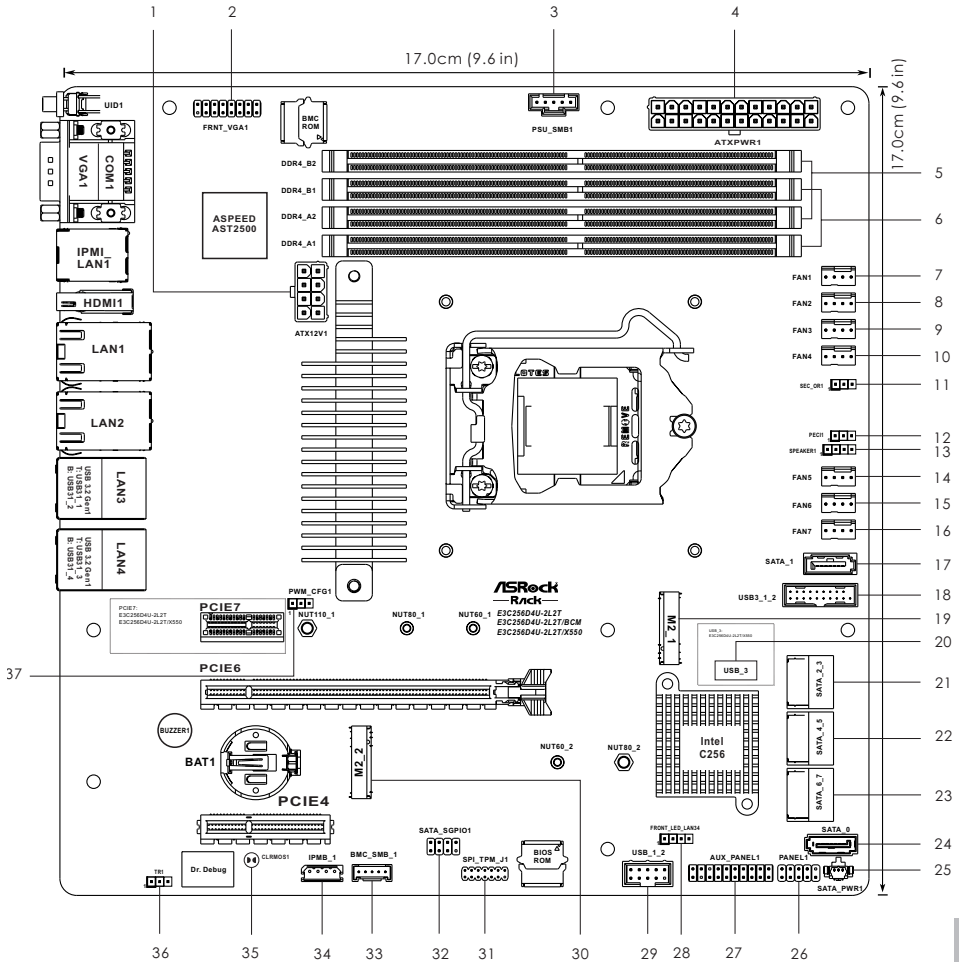

| No. | Description |
|-----|--|
| 1 | ATX 12V Power Connector (ATX12V1) |
| 2 | Front VGA Header (FRNT_VGA1) |
| 3 | PSU SMBus (PSU_SMB1) |
| 4 | ATX Power Connector (ATXPWR1) |
| 5 | 2 x 288-pin DDR4 DIMM Slots (DDR4_A2, DDR4_B2, Blue) |
| 6 | 2 x 288-pin DDR4 DIMM Slots (DDR4_A1, DDR4_B1, White) |
| 7 | System Fan Connector (FAN1) |
| 8 | System Fan Connector (FAN2) |
| 9 | System Fan Connector (FAN3) |
| 10 | System Fan Connector (FAN4) |
| 11 | Security Override Jumper (SEC_OR1) |
| 12 | CPU PECEI Mode Jumper (PECEI1) |
| 13 | Chassis Speaker Header (SPEAKER1) |
| 14 | System Fan Connector (FAN5) |
| 15 | System Fan Connector (FAN6) |
| 16 | System Fan Connector (FAN7) |
| 17 | SATA3 Connector (SATA_1) |
| 18 | USB 3.2 Gen1 Header (USB3_1_2) |
| 19 | M.2 Socket (M2_1) (Type 2260/2280/22110)* |
| 20 | Vertical Type A USB 2.0 Port (USB_3) <i>(for E3C256D4U-2L2T/X550 only)</i> |
| 21 | SATA3 Connectors (SATA3_3)(Upper), (SATA3_2)(Lower) |
| 22 | SATA3 Connectors (SATA3_5)(Upper), (SATA3_4)(Lower) |
| 23 | SATA3 Connectors (SATA3_7)(Upper), (SATA3_6)(Lower) |
| 24 | SATA3 DOM Connector (SATA_0), Red* |
| 25 | SATA DOM Power Header (SATA_PWR1) |
| 26 | System Panel Header (PANEL1) |
| 27 | Auxiliary Panel Header (AUX_PANEL1) |
| 28 | Front LAN LED Connector (FRONT_LED_LAN34) |
| 29 | USB 2.0 Header (USB_1_2) |
| 30 | M.2 Socket (M2_2) (Type 2260/2280) |
| 31 | TPM-SPI Header (SPI_TPM_J1) |
| 32 | SATA SGPIO Connector (SATA_SGPIO) |
| 33 | BMC SMBus Header (BMC_SMB_1) |
| 34 | Intelligent Platform Management Bus Header (IPMB_1) |

| No. | Description |
|-----|-------------------------------------|
| 35 | Clear CMOS Pad (CLRMOS1) |
| 36 | Thermal Sensor Header (TR1) |
| 37 | PWM Configuration Header (PWM_CFG1) |

**For DIMM installation and configuration instructions, please see p.28 (Installation of Memory Modules (DIMM)) for more details.*

***The M.2 slot (M2_1) is shared with the SATA_0 connector. When M2_1 is populated with a M.2 SATA3/PCIE3.0(x4 or x2) module, SATA_0 is disabled.*

E3C252D4U-2T
 E3C252D4U-2T/BCM
 E3C252D4U

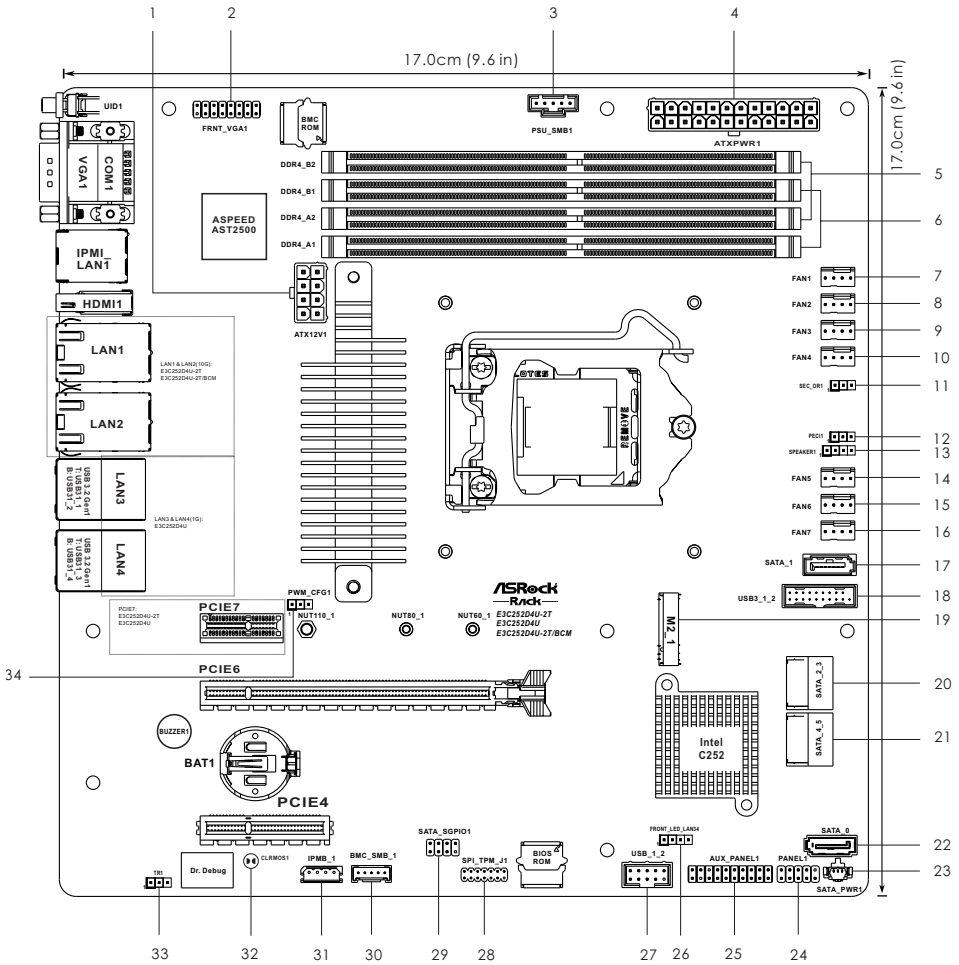

| No. | Description |
|-----|---|
| 1 | ATX 12V Power Connector (ATX12V1) |
| 2 | Front VGA Header (FRNT_VGA1) |
| 3 | PSU SMBus (PSU_SMB1) |
| 4 | ATX Power Connector (ATXPWR1) |
| 5 | 2 x 288-pin DDR4 DIMM Slots (DDR4_A2, DDR4_B2, Blue) |
| 6 | 2 x 288-pin DDR4 DIMM Slots (DDR4_A1, DDR4_B1, White) |
| 7 | System Fan Connector (FAN1) |
| 8 | System Fan Connector (FAN2) |
| 9 | System Fan Connector (FAN3) |
| 10 | System Fan Connector (FAN4) |
| 11 | Security Override Jumper (SEC_OR1) |
| 12 | CPU PECI Mode Jumper (PECI1) |
| 13 | Chassis Speaker Header (SPEAKER1) |
| 14 | System Fan Connector (FAN5) |
| 15 | System Fan Connector (FAN6) |
| 16 | System Fan Connector (FAN7) |
| 17 | SATA3 Connector (SATA_1) |
| 18 | USB 3.2 Gen1 Header (USB3_1_2) |
| 19 | M.2 Socket (M2_1) (Type 2260/2280/22110)* |
| 20 | SATA3 Connectors (SATA3_3)(Upper), (SATA3_2)(Lower) |
| 21 | SATA3 Connectors (SATA3_5)(Upper), (SATA3_4)(Lower) |
| 22 | SATA3 DOM Connector (SATA_0), Red* |
| 23 | SATA DOM Power Header (SATA_PWR1) |
| 24 | System Panel Header (PANEL1) |
| 25 | Auxiliary Panel Header (AUX_PANEL1) |
| 26 | Front LAN LED Connector (FRONT_LED_LAN34) |
| 27 | USB 2.0 Header (USB_1_2) |
| 28 | TPM-SPI Header (SPI_TPM_J1) |
| 29 | SATA SGPIO Connector (SATA_SGPIO1) |
| 30 | BMC SMBus Header (BMC_SMB_1) |
| 31 | Intelligent Platform Management Bus Header (IPMB_1) |
| 32 | Clear CMOS Pad (CLRMO1) |
| 33 | Thermal Sensor Header (TR1) |
| 34 | PWM Configuration Header (PWM_CFG1) |

**For DIMM installation and configuration instructions, please see p.28 (Installation of Memory Modules (DIMM)) for more details.*

***The M.2 slot (M2_1) is shared with the SATA_0 connector. When M2_1 is populated with a M.2 SATA3/PCIE3.0(x4 or x2) module, SATA_0 is disabled.*

1.5 Onboard LED Indicators

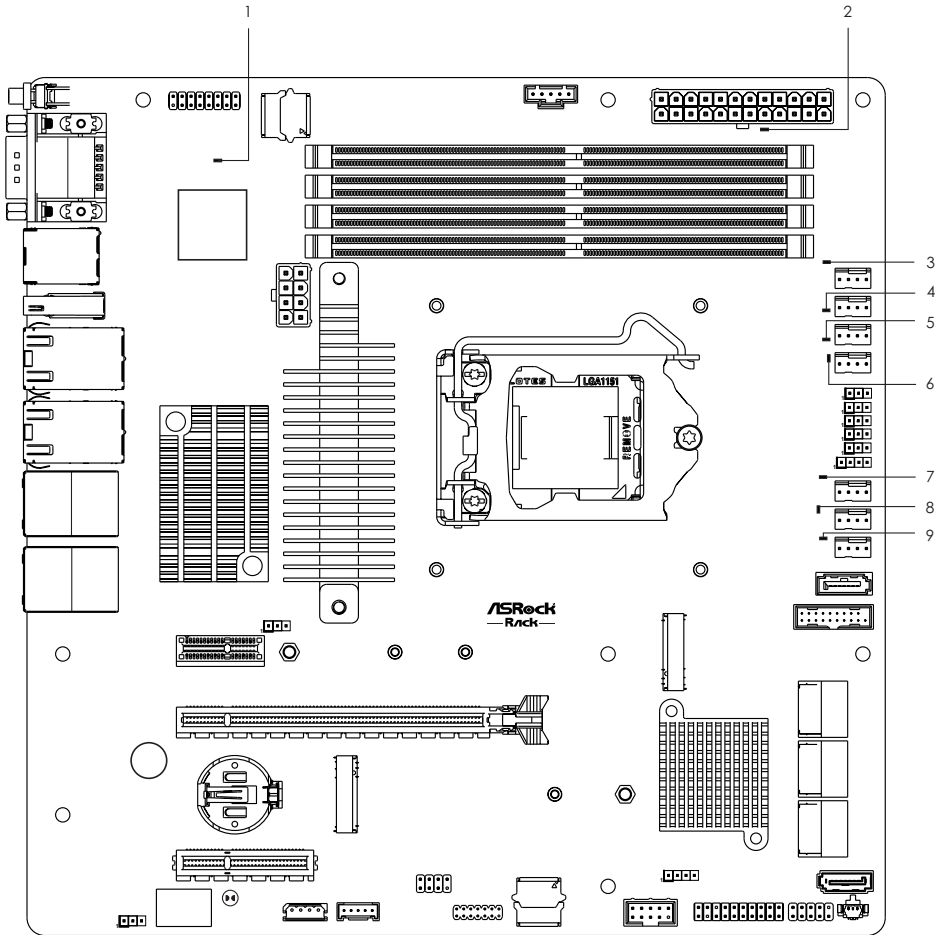

| No. | Item | Status | Description |
|-----|----------------|--------|-------------------|
| 1 | BMC_LED1 | Green | BMC heartbeat LED |
| 2 | SB_PWR1 | Green | STB PWR ready |
| 3 | CPU_FAN1_LED1 | Amber | FAN1 failed |
| 4 | FRNT_FAN2_LED1 | Amber | FAN2 failed |
| 5 | FRNT_FAN3_LED1 | Amber | FAN3 failed |
| 6 | FRNT_FAN4_LED1 | Amber | FAN4 failed |
| 7 | REAR_FAN1_LED1 | Amber | FAN5 failed |
| 8 | REAR_FAN2_LED1 | Amber | FAN6 failed |
| 9 | REAR_FAN3_LED1 | Amber | FAN7 failed |

1.6 I/O Panel

E3C256D4U-2L2T

E3C256D4U-2L2T/BCM

E3C256D4U-2L2T/X550

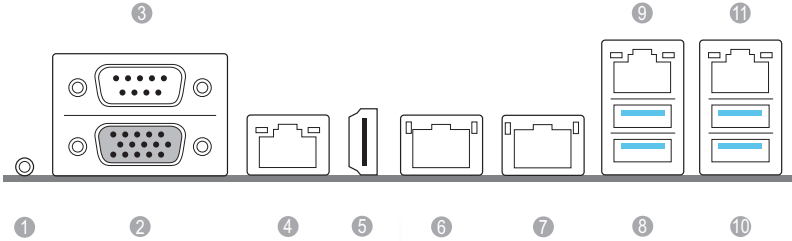

| No. | Description | No. | Description |
|-----|-----------------------------|-----|--------------------------------|
| 1 | UID Switch (UID1) | 7 | 10G LAN RJ-45 Port (LAN2)** |
| 2 | VGA Port (VGA1) | 8 | USB 3.2 Gen1 Ports (USB31_1_2) |
| 3 | Serial Port (COM1) | 9 | 1G LAN RJ-45 Port (LAN3)*** |
| 4 | LAN RJ-45 Port (IPMI_LAN)* | 10 | 1G LAN RJ-45 Port (LAN4)*** |
| 5 | HDMI Port (HDMI1) | 11 | USB 3.2 Gen1 Ports (USB31_3_4) |
| 6 | 10G LAN RJ-45 Port (LAN1)** | | |

Note: LAN1 supports NCSI.

E3C252D4U-2T
E3C252D4U-2T/BCM

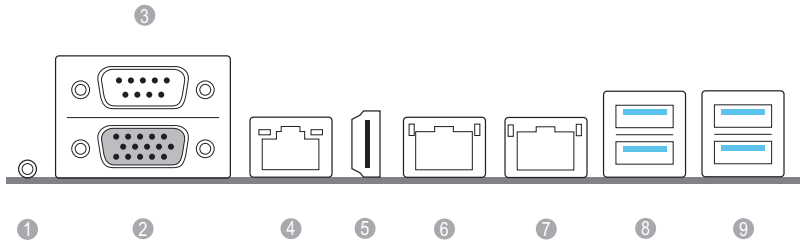

| No. | Description | No. | Description |
|-----|----------------------------|-----|--------------------------------|
| 1 | UID Switch (UID1) | 6 | 10G LAN RJ-45 Port (LAN1)** |
| 2 | VGA Port (VGA1) | 7 | 10G LAN RJ-45 Port (LAN2)** |
| 3 | Serial Port (COM1) | 8 | USB 3.2 Gen1 Ports (USB31_1_2) |
| 4 | LAN RJ-45 Port (IPMI_LAN)* | 9 | USB 3.2 Gen1 Ports (USB31_3_4) |
| 5 | HDMI Port (HDMI1) | | |

Note: LAN1 supports NCSI.

E3C252D4U

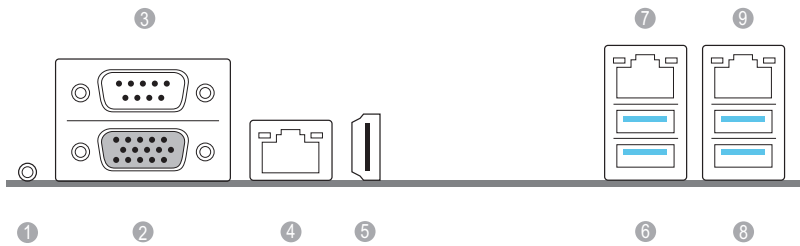

| No. | Description | No. | Description |
|-----|----------------------------|-----|--------------------------------|
| 1 | UID Switch (UID1) | 6 | USB 3.2 Gen1 Ports (USB31_1_2) |
| 2 | VGA Port (VGA1) | 7 | 1G LAN RJ-45 Port (LAN3)*** |
| 3 | Serial Port (COM1) | 8 | 1G LAN RJ-45 Port (LAN4)*** |
| 4 | LAN RJ-45 Port (IPMI_LAN)* | 9 | USB 3.2 Gen1 Ports (USB31_3_4) |
| 5 | HDMI Port (HDMI1) | | |

Note: LAN3 supports NCSI.

LAN Port LED Indications

*There are two LED next to the LAN port. Please refer to the table below for the LAN port LED indications.

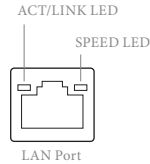

Dedicated IPMI LAN Port LED Indications

| Activity / Link LED | | Speed LED | |
|---------------------|---------------|-----------|-------------------------------|
| Status | Description | Status | Description |
| Off | No Link | Off | 10M bps connection or no link |
| Blinking Green | Data Activity | Off | 100M bps connection |
| On | Link | Yellow | 1Gbps connection |

**There are two LEDs on each LAN port. Please refer to the table below for the LAN port LED indications.

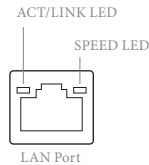

1G LAN Port LED (LAN3, LAN4)Indications

| Activity / Link LED | | Speed LED | |
|---------------------|---------------|-----------|------------------------------|
| Status | Description | Status | Description |
| Off | No Link | Off | 10Mbps connection or no link |
| Blinking Green | Data Activity | Yellow | 100Mbps connection |
| On | Link | Green | 1Gbps connection |

***There are two LEDs on each LAN port. Please refer to the table below for the LAN port LED indications.

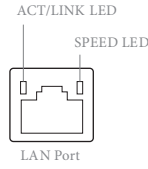

10G LAN Port (LAN1, LAN2) LED Indications

| Activity / Link LED | | Speed LED | |
|---------------------|---------------|-----------|-------------------------------|
| Status | Description | Status | Description |
| Off | No Link | Off | 100Mbps connection or no link |
| Blinking Yellow | Data Activity | Yellow | 1Gbps connection |
| On | Link | Green | 10Gbps connection |

1.7 Block Diagram

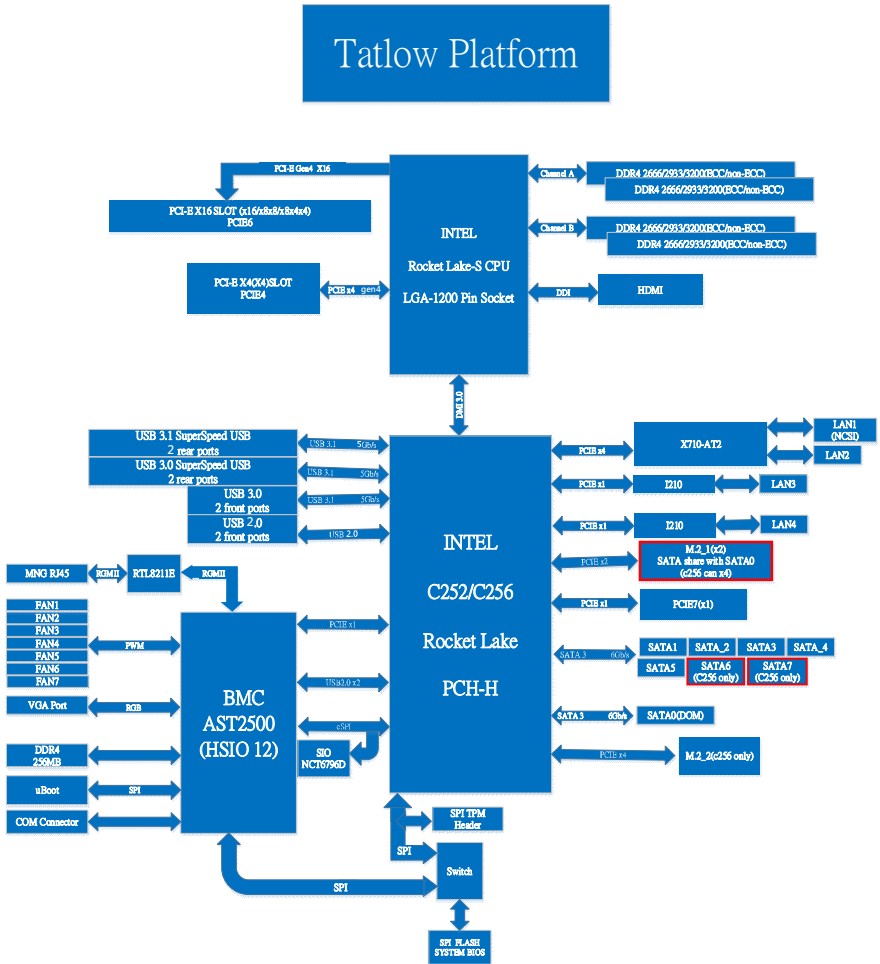

Chapter 2 Installation

This is a mATX form factor (9.6" x 9.6", 24.4 cm x 24.4 cm) motherboard. Before you install the motherboard, study the configuration of your chassis to ensure that the motherboard fits into it.



Make sure to unplug the power cord before installing or removing the motherboard. Failure to do so may cause physical injuries to you and damages to motherboard components.

2.1 Screw Holes

Place screws into the holes indicated by circles to secure the motherboard to the chassis.



Do not over-tighten the screws! Doing so may damage the motherboard.

2.2 Pre-installation Precautions

Take note of the following precautions before you install motherboard components or change any motherboard settings.

1. Unplug the power cord from the wall socket before touching any components.
2. To avoid damaging the motherboard's components due to static electricity, NEVER place your motherboard directly on the carpet or the like. Also remember to use a grounded wrist strap or touch a safety grounded object before you handle the components.
3. Hold components by the edges and do not touch the ICs.
4. Whenever you uninstall any component, place it on a grounded anti-static pad or in the bag that comes with the component.
5. When placing screws into the screw holes to secure the motherboard to the chassis, please do not over-tighten the screws! Doing so may damage the motherboard.



Before you install or remove any component, ensure that the power is switched off or the power cord is detached from the power supply. Failure to do so may cause severe damage to the motherboard, peripherals, and/or components.

2.3 Installing the CPU



1. Before you insert the 1151-Pin CPU into the socket, please check if the PnP cap is on the socket, if the CPU surface is unclean, or if there are any bent pins in the socket. Do not force to insert the CPU into the socket if above situation is found. Otherwise, the CPU will be seriously damaged.
2. Unplug all power cables before installing the CPU.



Illustrations in this User Manual are provided for reference only and may slightly differ from actual product appearances.

1

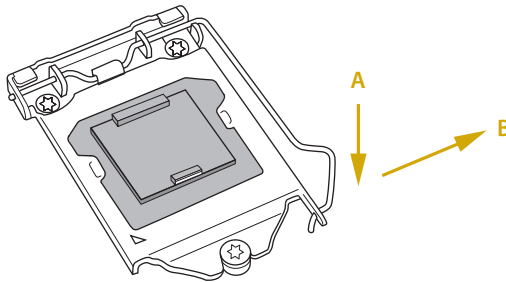

2

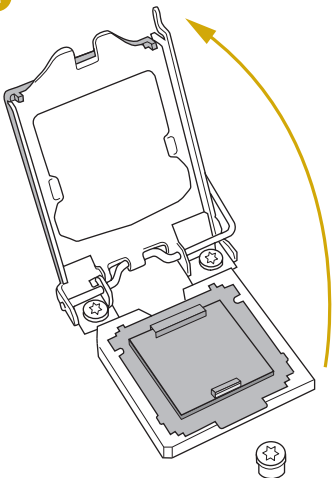

3

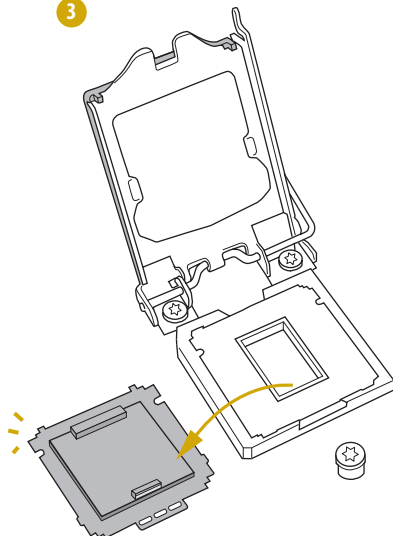

4

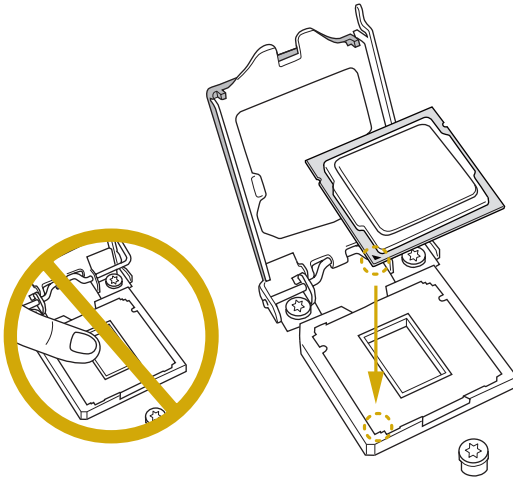

5

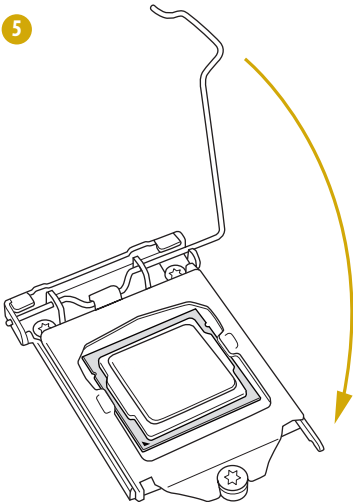

6

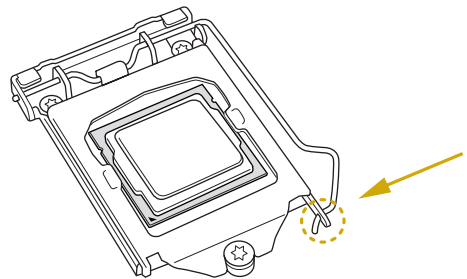

Please save and replace the cover if the processor is removed. The cover must be placed if you wish to return the motherboard for after service.

2.4 Installing the CPU Fan and Heatsink

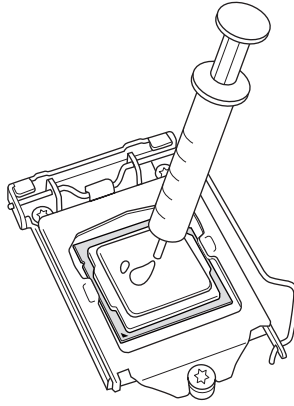
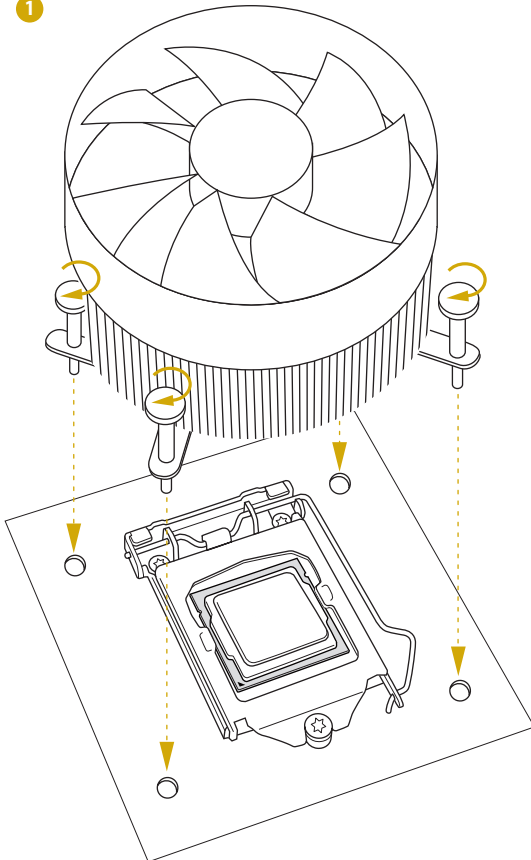
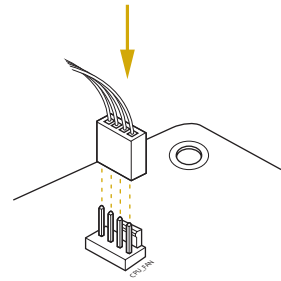
**1****2**

2.5 Installation of Memory Modules (DIMM)

This motherboard provides four 288-pin DDR4 (Double Data Rate 4) DIMM slots, and supports Dual Channel Memory Technology.



1. For dual channel configuration, you always need to install identical (the same brand, speed, size and chip-type) DDR4 DIMM pairs.
2. It is unable to activate Dual Channel Memory Technology with only one or three memory module installed.
3. It is not allowed to install a DDR, DDR2 or DDR3 memory module into a DDR4 slot; otherwise, this motherboard and DIMM may be damaged.

A single memory module should be installed in the BLUE socket.

Dual Channel Memory Configuration

| Priority | DDR4_A1 | DDR4_A2 | DDR4_B1 | DDR4_B2 |
|----------|-----------|-----------|-----------|-----------|
| 1 | | Populated | | Populated |
| 2 | Populated | | Populated | |
| 3 | Populated | Populated | Populated | Populated |



The DIMM only fits in one correct orientation. It will cause permanent damage to the motherboard and the DIMM if you force the DIMM into the slot at incorrect orientation.

1

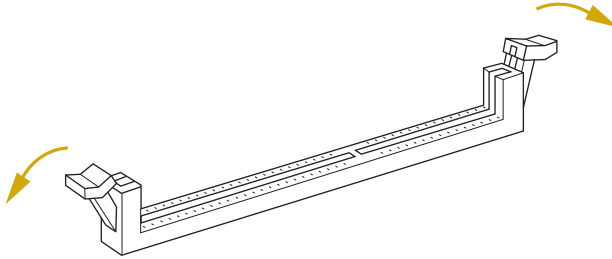

2

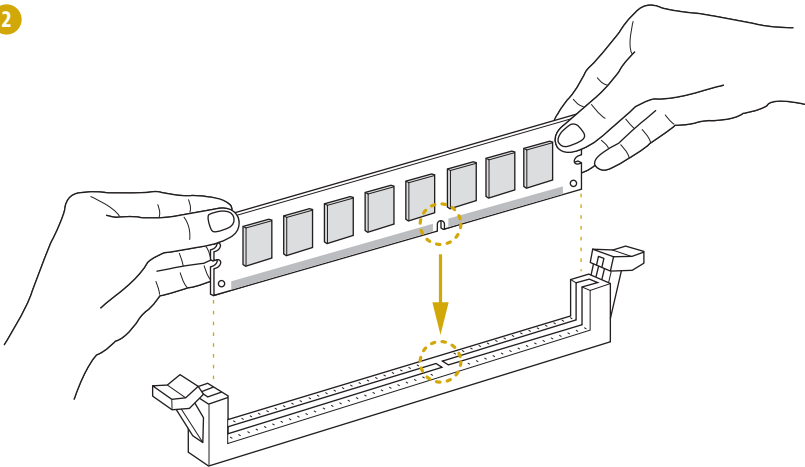

3

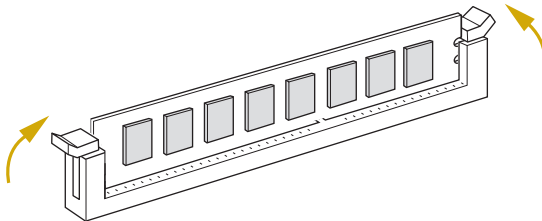

The DIMM only fits in one correct orientation. It will cause permanent damage to the motherboard and the DIMM if you force the DIMM into the slot at incorrect orientation.

2.6 Expansion Slots (PCI Express Slots)

There are 3 PCI Express slots on this motherboard.

PCIe slot:

PCIe4 (PCIe 4.0 x4 slot) is used for PCI Express x4 lane width cards.

PCIe6 (PCIe 4.0 x16 slot) is used for PCI Express x16 lane width cards.

PCIe7 (PCIe 3.0 x1 slot) is used for PCI Express x1 lane width cards. *(PCIe 7: for E3C256D4U-2L2T / E3C252D4U-2T / E3C252D4U / E3C256D4U-2L2T/X550 only)*

| Slot | Generation | Mechanical | Electrical | Source |
|--------|------------|------------|------------|--------|
| PCIe 7 | 3.0 | x1 | x1 | PCH |
| PCIe 6 | 4.0 | x16 | x16 | CPU |
| PCIe 4 | 4.0 | x4 | x4 | CPU |

**SLOT6 supports PCIe3.0 only and SLOT4 will not function when installing Pentium Series Processors*

Installing an expansion card

- Step 1. Before installing an expansion card, please make sure that the power supply is switched off or the power cord is unplugged. Please read the documentation of the expansion card and make necessary hardware settings for the card before you start the installation.
- Step 2. Remove the system unit cover (if your motherboard is already installed in a chassis).
- Step 3. Remove the bracket facing the slot that you intend to use. Keep the screws for later use.
- Step 4. Align the card connector with the slot and press firmly until the card is completely seated on the slot.
- Step 5. Fasten the card to the chassis with screws.
- Step 6. Replace the system cover.

2.7 Jumper Setup

The illustration shows how jumpers are setup. When the jumper cap is placed on the pins, the jumper is “Short”. If no jumper cap is placed on the pins, the jumper is “Open”. The illustration shows a 3-pin jumper whose pin1 and pin2 are “Short” when a jumper cap is placed on these 2 pins.

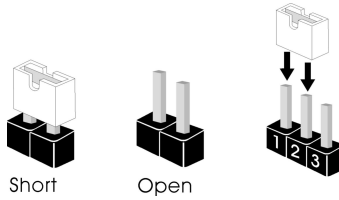

CPU PECI Mode Jumper
(3-pin PECI1)



CPU PECI connected to
PCH



CPU PECI connected to
BMC (Default)

Security Override Jumper
(3-pin SEC_OR1)



Descriptor Security
Override



Not override (Default)

2.8 Onboard Headers and Connectors



Onboard headers and connectors are NOT jumpers. Do NOT place jumper caps over these headers and connectors. Placing jumper caps over the headers and connectors will cause permanent damage to the motherboard.

System Panel Header (9-pin PANEL1)

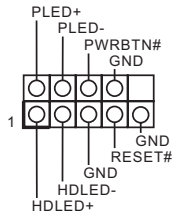

Connect the power switch, reset switch and system status indicator on the chassis to this header according to the pin assignments. Particularly note the positive and negative note before connecting the cables.



PWRBTN (Power Switch):

Connect to the power switch on the chassis front panel. You may configure the way to turn off your system using the power switch.

RESET (Reset Switch):

Connect to the reset switch on the chassis front panel. Press the reset switch to restart the computer if the computer freezes and fails to perform a normal restart.

PLED (System Power LED):

Connect to the power status indicator on the chassis front panel. The LED is on when the system is operating. The LED is off when the system is in S4 sleep state or powered off (S5).

HDLED (Hard Drive Activity LED):

Connect to the hard drive activity LED on the chassis front panel. The LED is on when the hard drive is reading or writing data.

The front panel design may differ by chassis. A front panel module mainly consists of power switch, reset switch, power LED, hard drive activity LED, speaker and etc. When connecting your chassis front panel module to this header, make sure the wire assignments and the pin assignments are matched correctly.

Auxiliary Panel Header (18-pin AUX PANEL1)

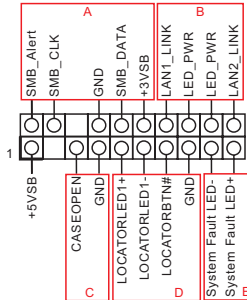

This header supports multiple functions on the front panel, including the front panel SMB, internet status indicator and chassis intrusion pin.



A. Front panel SMBus connecting pin (6-pin FPSMB)

This header allows you to connect SMBus (System Management Bus) equipment. It can be used for communication between peripheral equipment in the system, which has slower transmission rates, and power management equipment.

B. Internet status indicator (2-pin LAN1_LED, LAN2_LED)

These two 2-pin headers allow you to use the Gigabit internet indicator cable to connect to the LAN status indicator. When this indicator flickers, it means that the internet is properly connected.

C. Chassis intrusion pin (2-pin CHASSIS)

This header is provided for host computer chassis with chassis intrusion detection designs. In addition, it must also work with external detection equipment, such as a chassis intrusion detection sensor or a microswitch. When this function is activated, if any chassis component movement occurs, the sensor will immediately detect it and send a signal to this header, and the system will then record this chassis intrusion event. The default setting is set to the CASEOPEN and GND pin; this function is off.

D. Locator LED (4-pin LOCATOR)

This header is for the locator switch and LED on the front panel.

E. System Fault LED (2-pin LOCATOR)

This header is for the Fault LED on the system.

Serial ATA3 Connectors

Vertical:

(SATA_1)



Right-Angle:

(SATA_3)(Upper)

(SATA_2)(Lower)

(SATA_5)(Upper)

(SATA_4)(Lower)



E3C256D4U-2L2T

E3C256D4U-2L2T/BCM

E3C256D4U-2L2T/X550

only:

(SATA_7)(Upper)

(SATA_6)(Lower)



These seven SATA3 connectors support SATA data cables for internal storage devices with up to 6.0 Gb/s data transfer rate.

Serial ATA3 DOM

Connector

(SATA_0)



The SATA3 DOM connector supports both a SATA DOM (Disk-On-Module) and a SATA data cable for internal storage device.

**The M.2 slot (M2_1) is shared with the SATA_0 connector. When M2_1 is populated with a M.2 SATA3/PCIE3.0(x4 or x2) module, SATA_0 is disabled.*

SATA DOM Power

Connectors

(3-pin SATA_PWR1)

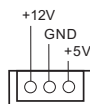

Please connect the power cable on the SATA DOM to the connector.

USB 3.2 Gen1 Header
(19-pin USB3_1_2)

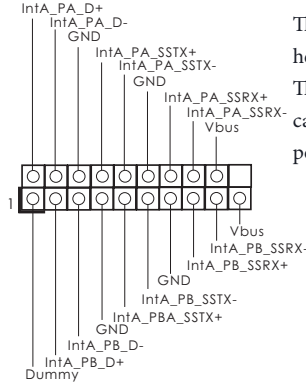

There is one USB 3.2 Gen1 header on this motherboard. This USB 3.2 Gen1 header can support two USB 3.2 Gen1 ports.

USB 2.0 Header
(9-pin USB_1_2)

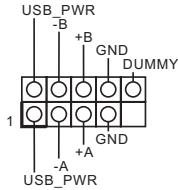

There is one USB 2.0 header on this motherboard. Each USB 2.0 header can support two ports.

E3C256D4U-2L2T/X550 only:
Vertical Type A USB 2.0
(USB_3)



There is one vertical Type A USB 2.0 port on this motherboard.

Chassis Speaker Header
(4-pin SPEAKER1)

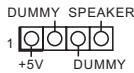

Please connect the chassis speaker to this header.

System Connectors
(4-pin FAN1)
(4-pin FAN2)
(4-pin FAN3)
(4-pin FAN4)
(4-pin FAN5)
(4-pin FAN6)
(4-pin FAN7)

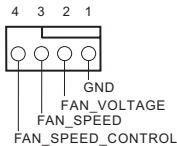

Please connect fan cables to the fan connectors and match the black wire to the ground pin. All fans support Fan Control.

Intelligent Platform
Management Bus Header
(4-pin IPMB_1)

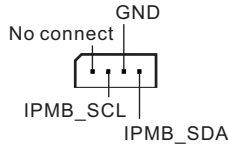

This 4-pin connector is used to provide a cabled base-board or front panel connection for value added features and 3rd-party add-in cards, such as Emergency Management cards, that provide management features using the IPMB.

Baseboard Management
Controller SMBus Header
(5-pin BMC_SMB_1)

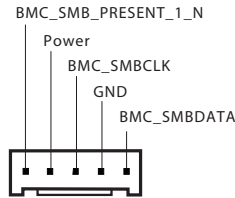

The header is used for the SMBUS devices.

Thermal Sensor Header
(3-pin TR1)



Please connect the thermal sensor cable to either pin 1-2 or pin 2-3 and the other end to the device which you wish to monitor its temperature.

PWM Configuration
Header
(3-pin PWM_CFG1)

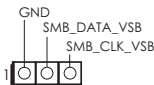

This header is used for PWM configurations.

Front LAN LED Header
(FRONT_LED_LAN34)

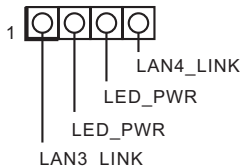

This 4-pin connector is used for the front LAN status indicator.

Clear CMOS Pad
(CLR_CMOS1)



This allows you to clear the data in CMOS. To clear CMOS, take out the CMOS battery and short the Clear CMOS Pad.

2.9 Dr. Debug

Dr. Debug is used to provide code information, which makes troubleshooting even easier. Please see the diagrams below for reading the Dr. Debug codes.

| Code | Description |
|------|----------------------|
| 0x10 | PEI_CORE_STARTED |
| 0x11 | PEI_CAR_CPU_INIT |
| 0x15 | PEI_CAR_NB_INIT |
| 0x19 | PEI_CAR_SB_INIT |
| 0x31 | PEI_MEMORY_INSTALLED |
| 0x32 | PEI_CPU_INIT |
| 0x33 | PEI_CPU_CACHE_INIT |
| 0x34 | PEI_CPU_AP_INIT |
| 0x35 | PEI_CPU_BSP_SELECT |
| 0x36 | PEI_CPU_SMM_INIT |
| 0x37 | PEI_MEM_NB_INIT |
| 0x3B | PEI_MEM_SB_INIT |
| 0x4F | PEI_DXE_IPL_STARTED |
| 0x60 | DXE_CORE_STARTED |
| 0x61 | DXE_NVRAM_INIT |
| 0x62 | DXE_SBRUN_INIT |

| | |
|------|-------------------------------|
| 0x63 | DXE_CPU_INIT |
| 0x68 | DXE_NB_HB_INIT |
| 0x69 | DXE_NB_INIT |
| 0x6A | DXE_NB_SMM_INIT |
| 0x70 | DXE_SB_INIT |
| 0x71 | DXE_SB_SMM_INIT |
| 0x72 | DXE_SB_DEVICES_INIT |
| 0x78 | DXE_ACPI_INIT |
| 0x79 | DXE_CSM_INIT |
| 0x90 | DXE_BDS_STARTED |
| 0x91 | DXE_BDS_CONNECT_DRIVERS |
| 0x92 | DXE_PCI_BUS_BEGIN |
| 0x93 | DXE_PCI_BUS_HPC_INIT |
| 0x94 | DXE_PCI_BUS_ENUM |
| 0x95 | DXE_PCI_BUS_REQUEST_RESOURCES |
| 0x96 | DXE_PCI_BUS_ASSIGN_RESOURCES |
| 0x97 | DXE_CON_OUT_CONNECT |
| 0x98 | DXE_CON_IN_CONNECT |

| | |
|------|------------------------------|
| 0x99 | DXE_SIO_INIT |
| 0x9A | DXE_USB_BEGIN |
| 0x9B | DXE_USB_RESET |
| 0x9C | DXE_USB_DETECT |
| 0x9D | DXE_USB_ENABLE |
| 0xA0 | DXE_IDE_BEGIN |
| 0xA1 | DXE_IDE_RESET |
| 0xA2 | DXE_IDE_DETECT |
| 0xA3 | DXE_IDE_ENABLE |
| 0xA4 | DXE_SCSI_BEGIN |
| 0xA5 | DXE_SCSI_RESET |
| 0xA6 | DXE_SCSI_DETECT |
| 0xA7 | DXE_SCSI_ENABLE |
| 0xA8 | DXE_SETUP_VERIFYING_PASSWORD |
| 0xA9 | DXE_SETUP_START |
| 0xAB | DXE_SETUP_INPUT_WAIT |
| 0xAD | DXE_READY_TO_BOOT |
| 0xAE | DXE_LEGACY_BOOT |

| | |
|------|----------------------------------|
| 0xAF | DXE_EXIT_BOOT_SERVICES |
| 0xB0 | RT_SET_VIRTUAL_ADDRESS_MAP_BEGIN |
| 0xB1 | RT_SET_VIRTUAL_ADDRESS_MAP_END |
| 0xB2 | DXE_LEGACY_OPROM_INIT |
| 0xB3 | DXE_RESET_SYSTEM |
| 0xB4 | DXE_USB_HOTPLUG |
| 0xB5 | DXE_PCI_BUS_HOTPLUG |
| 0xB6 | DXE_NVRAM_CLEANUP |
| 0xB7 | DXE_CONFIGURATION_RESET |
| 0xF0 | PEI_RECOVERY_AUTO |
| 0xF1 | PEI_RECOVERY_USER |
| 0xF2 | PEI_RECOVERY_STARTED |
| 0xF3 | PEI_RECOVERY_CAPSULE_FOUND |
| 0xF4 | PEI_RECOVERY_CAPSULE_LOADED |
| 0xE0 | PEI_S3_STARTED |
| 0xE1 | PEI_S3_BOOT_SCRIPT |
| 0xE2 | PEI_S3_VIDEO_REPOST |

| | |
|------|---------------------------------|
| 0xE3 | PEI_S3_OS_WAKE |
| 0x50 | PEI_MEMORY_INVALID_TYPE |
| 0x53 | PEI_MEMORY_NOT_DETECTED |
| 0x55 | PEI_MEMORY_NOT_INSTALLED |
| 0x57 | PEI_CPU_MISMATCH |
| 0x58 | PEI_CPU_SELF_TEST_FAILED |
| 0x59 | PEI_CPU_NO_MICROCODE |
| 0x5A | PEI_CPU_ERROR |
| 0x5B | PEI_RESET_NOT_AVAILABLE |
| 0xD0 | DXE_CPU_ERROR |
| 0xD1 | DXE_NB_ERROR |
| 0xD2 | DXE_SB_ERROR |
| 0xD3 | DXE_ARCH_PROTOCOL_NOT_AVAILABLE |
| 0xD4 | DXE_PCI_BUS_OUT_OF_RESOURCES |
| 0xD5 | DXE_LEGACY_OPROM_NO_SPACE |
| 0xD6 | DXE_NO_CON_OUT |
| 0xD7 | DXE_NO_CON_IN |

| | |
|------|-----------------------------|
| 0xD8 | DXE_INVALID_PASSWORD |
| 0xD9 | DXE_BOOT_OPTION_LOAD_ERROR |
| 0xDA | DXE_BOOT_OPTION_FAILED |
| 0xDB | DXE_FLASH_UPDATE_FAILED |
| 0xDC | DXE_RESET_NOT_AVAILABLE |
| 0xE8 | PEI_MEMORY_S3_RESUME_FAILED |
| 0xE9 | PEI_S3_RESUME_PPI_NOT_FOUND |
| 0xEA | PEI_S3_BOOT_SCRIPT_ERROR |
| 0xEB | PEI_S3_OS_WAKE_ERROR |

2.10 Unit Identification purpose LED/Switch

With the UID button, You are able to locate the server you're working on from behind a rack of servers.

Unit Identification
purpose LED/Switch
(UID1)



When the UID button on the front or rear panel is pressed, the front/rear UID blue LED indicator will be turned on. Press the UID button again to turn off the indicator.

2.11 Dua LAN and Teaming Operation Guide

Dual LAN with Teaming enabled on this motherboard allows two single connections to act as one single connection(s) for twice the transmission bandwidth, making data transmission more effective and improving the quality of transmission of distant images. Fault tolerance on the dual LAN network prevents network downtime by transferring the workload from a failed port to a working port.



The speed of transmission is subject to the actual network environment or status even with Teaming enabled.

Before setting up Teaming, please make sure whether your Switch (or Router) supports Teaming (IEEE 802.3ad Link Aggregation). You can specify a preferred adapter in Intel PROSet. Under normal conditions, the Primary adapter handles all non-TCP/IP traffic. The Secondary adapter will receive fallback traffic if the primary fails. If the Preferred Primary adapter fails, but is later restored to an active status, control is automatically switched back to the Preferred Primary adapter.

Step 1

From **Device Manager**, open the properties of a team.

Step 2

Click the **Settings** tab.

Step 3

Click the **Modify Team** button.

Step 4

Select the adapter you want to be the primary adapter and click the **Set Primary** button.

If you do not specify a preferred primary adapter, the software will choose an adapter of the highest capability (model and speed) to act as the default primary. If a failover occurs, another adapter becomes the primary. The adapter will, however, rejoin the team as a non-primary.

2.12 M.2 SSD Module Installation Guide (M2_1)

The M.2 Socket (M2_1, Key M) supports a type 2260/2280/22110 M.2 SATA3 6.0 Gb/s module or a M.2 PCI Express module up to Gen3 x4 (8GT/s x4) (for E3C256D4U-2L2T/ E3C256D4U-2L2T/BCM / E3C256D4U-2L2T/X550 only).

The M.2 Socket (M2_1, Key M) supports a type 2260/2280/22110 M.2 SATA3 6.0 Gb/s module or a M.2 PCI Express module up to Gen3 x2(8GT/s x2) (for E3C252D4U-2T / E3C252D4U-2T/BCM / E3C252D4U only).

***The M.2 slot (M2_1) is shared with the SATA_0 connector. When M2_1 is populated with a M.2 SATA3/ PCIE3.0(x4 or x2) module, SATA_0 is disabled.*

Installing the M.2 SSD Module

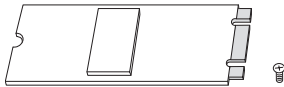

Step 1

Prepare a M.2 SSD module and the screw.

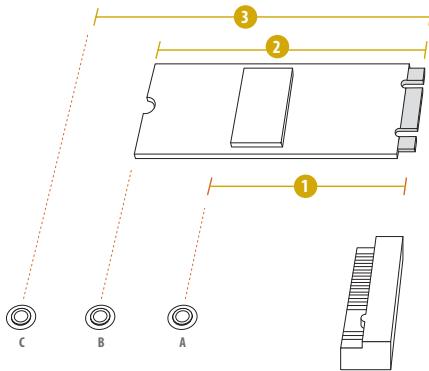

Step 2

Depending on the PCB type and length of your M.2 SSD module, find the corresponding nut location to be used.

| No. | 1 | 2 | 3 |
|--------------|-----------|-----------|------------|
| Nut Location | NUT60 | NUT80 | NUT110 |
| PCB Length | 6cm | 8cm | 11cm |
| Module Type | Type 2260 | Type 2280 | Type 22110 |

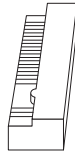
**Step 3**

Move the standoff based on the module type and length.
Skip Step 3 and 4 and go straight to Step 5 if you are going to use the default nut.
Otherwise, release the standoff by hand.

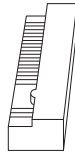
**Step 4**

Peel off the yellow protective film on the nut to be used. Hand tighten the standoff into the desired nut location on the motherboard.

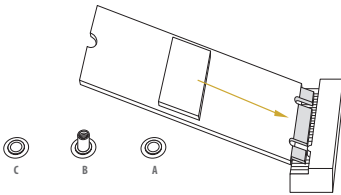
**Step 5**

Align and gently insert the M.2 SSD module into the M.2 slot. Please be aware that the M.2 SSD module only fits in one orientation.

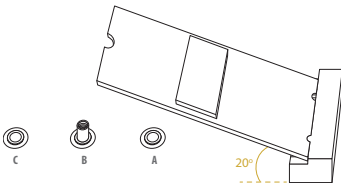
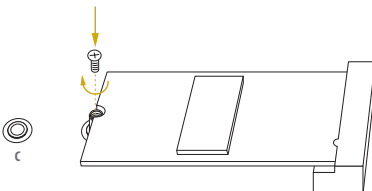
**Step 6**

Tighten the screw with a screwdriver to secure the module into place. Please do not overtighten the screw as this might damage the module.

2.13 M.2 SSD Module Installation Guide (M2_2)

The M.2 Socket (M2_2, Key M) supports type 2260/2280 M.2 PCI Express module up to Gen3 x4 (8GT/s x4). *(for E3C256D4U-2L2T / E3C256D4U-2L2T/BCM / E3C256D4U-2L2T/X550 only)*

Installing the M.2 SSD Module

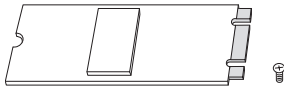

Step 1

Prepare a M.2 SSD module and the screw.

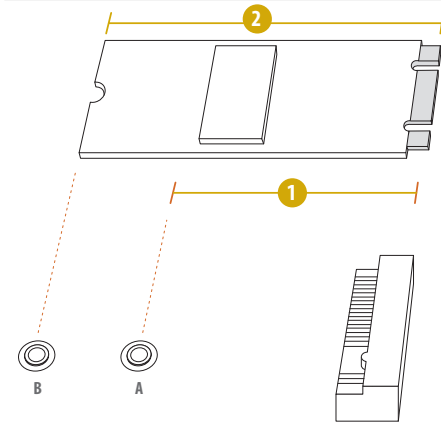

Step 2

Depending on the PCB type and length of your M.2 SSD module, find the corresponding nut location to be used.

| No. | 1 | 2 |
|--------------|-----------|-----------|
| Nut Location | A | B |
| PCB Length | 6cm | 8cm |
| Module Type | Type 2260 | Type 2280 |

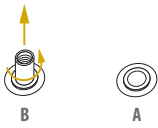
**Step 3**

Move the standoff based on the module type and length.
Skip Step 3 and 4 and go straight to Step 5 if you are going to use the default nut.
Otherwise, release the standoff by hand.

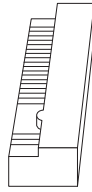
**Step 4**

Peel off the yellow protective film on the nut to be used. Hand tighten the standoff into the desired nut location on the motherboard.

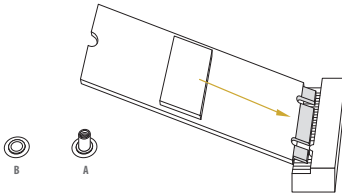
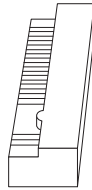
**Step 5**

Align and gently insert the M.2 SSD module into the M.2 slot. Please be aware that the M.2 SSD module only fits in one orientation.

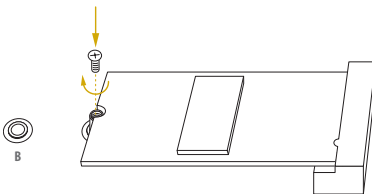
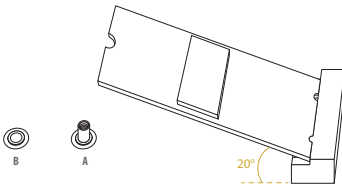
**Step 6**

Tighten the screw with a screwdriver to secure the module into place. Please do not overtighten the screw as this might damage the module.

Chapter 3 UEFI Setup Utility

3.1 Introduction

This section explains how to use the UEFI SETUP UTILITY to configure your system. The UEFI chip on the motherboard stores the UEFI SETUP UTILITY. You may run the UEFI SETUP UTILITY when you start up the computer. Please press <F2> or during the Power-On-Self-Test (POST) to enter the UEFI SETUP UTILITY; otherwise, POST will continue with its test routines.

If you wish to enter the UEFI SETUP UTILITY after POST, restart the system by pressing <Ctrl> + <Alt> + <Delete>, or by pressing the reset button on the system chassis. You may also restart by turning the system off and then back on.



Because the UEFI software is constantly being updated, the following UEFI setup screens and descriptions are for reference purpose only, and they may not exactly match what you see on your screen.

3.1.1 UEFI Menu Bar

The top of the screen has a menu bar with the following selections:

| Item | Description |
|-------------|---|
| Main | To set up the system time/date information |
| Advanced | To set up the advanced UEFI features |
| Server Mgmt | To manage the server |
| Security | To set up the security features |
| Boot | To set up the default system device to locate and load the Operating System |
| Event Logs | For event log configuration |
| Exit | To exit the current screen or the UEFI SETUP UTILITY |

Use <←> key or <→> key to choose among the selections on the menu bar, and then press <Enter> to get into the sub screen.

3.1.2 Navigation Keys

Please check the following table for the function description of each navigation key.

| Navigation Key(s) | Function Description |
|-------------------|--|
| ← / → | Moves cursor left or right to select Screens |
| ↑ / ↓ | Moves cursor up or down to select items |
| + / - | To change option for the selected items |
| <Tab> | Switch to next function |
| <Enter> | To bring up the selected screen |
| <PGUP> | Go to the previous page |
| <PGDN> | Go to the next page |
| <HOME> | Go to the top of the screen |
| <END> | Go to the bottom of the screen |
| <F1> | To display the General Help Screen |
| <F7> | Discard changes and exit the UEFI SETUP UTILITY |
| <F9> | Load optimal default values for all the settings |
| <F10> | Save changes and exit the UEFI SETUP UTILITY |
| <F12> | Print screen |
| <ESC> | Jump to the Exit Screen or exit the current screen |

3.2 Main Screen

Once you enter the UEFI SETUP UTILITY, the Main screen will appear and display the system overview. The Main screen provides system overview information and allows you to set the system time and date.

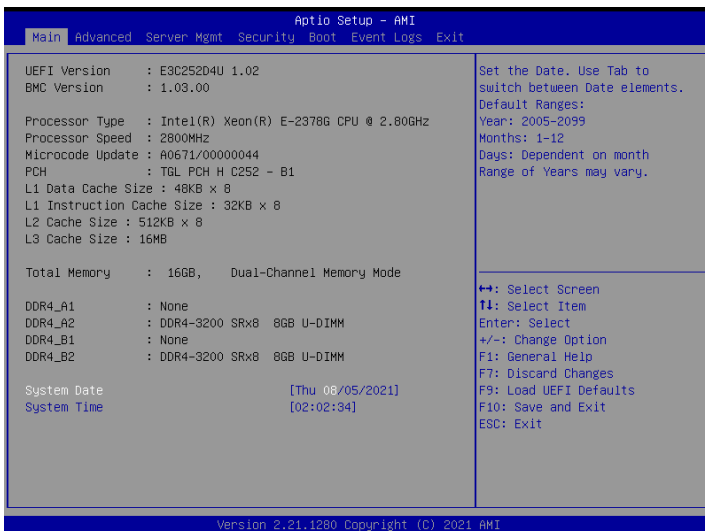

3.3 Advanced Screen

In this section, you may set the configurations for the following items: CPU Configuration, DRAM Configuration, Chipset Configuration, Storage Configuration, NVMe Configuration, ACPI Configuration, Super IO Configuration, Serial Port Console Redirection, H/W Monitor, Intel SPS Configuratio, Driver Health, Network Stack Configuration, Tls Auth Configuration, RAM Disk Configuration, iSCSI Configuration and Instant Flash.

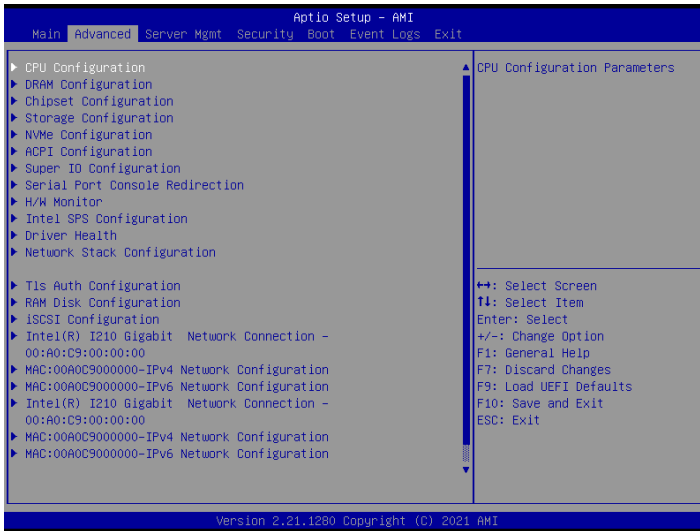

Save User Default

Type a profile name and press enter to save your settings as user default.

Load User Default

Load previously saved user defaults.



Setting wrong values in this section may cause the system to malfunction.

3.3.1 CPU Configuration

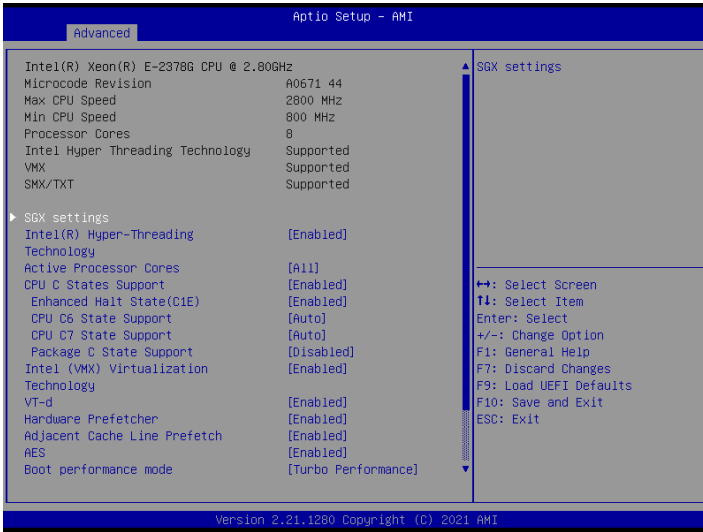

SGX settings

Software Guard Extensions (SGX)

Use this item to enable or disable Software Controlled Software Guard Extensions (SGX).

Hyper-Threading *(Supported depending on your CPU)*

Intel Hyper Threading Technology allows multiple threads to run on each core, so that the overall performance on threaded software is improved.

Active Processor Cores

Select the number of cores to enable in each processor package.

CPU C States Support

Enable CPU C States Support for power saving. It is recommended to keep C6 and C7 all enabled for better power saving.

Enhanced Halt State (C1E)

Enable Enhanced Halt State (C1E) for lower power consumption.

CPU C6 State Support

Enable C6 deep sleep state for lower power consumption.

CPU C7 State Support

Enable C7 deep sleep state for lower power consumption.

Package C State Support

Enable CPU, PCIe, Memory, Graphics C State Support for power saving.

Intel (VMX) Virtualization Technology

When enabled, a VMM can utilize the additional hardware capabilities provided by Vanderpool Technology.

VT-d

Intel® Virtualization Technology for Directed I/O helps your virtual machine monitor better utilize hardware by improving application compatibility and reliability, and providing additional levels of manageability, security, isolation, and I/O performance.

Hardware Prefetcher

Automatically prefetch data and code for the processor. Enable for better performance.

Adjacent Cache Line Prefetch

Automatically prefetch the subsequent cache line while retrieving the currently requested cache line. Enable for better performance.

AES

Use this to enable or disable CPU Advanced Encryption Standard instructions.

Boot Performance Mode

Use this to item to select the performance state that the BIOS will set starting from reset vector.

Intel SpeedStep Technology

Intel SpeedStep technology allows processors to switch between multiple frequencies and voltage points for better power saving and heat dissipation. CPU turbo ratio can be fixed when Intel SpeedStep Technology is set to Disabled and Intel Turbo Boost Technology is set to Enabled.



Please note that enabling this function may reduce CPU voltage and lead to system stability or compatibility issues with some power supplies. Please set this item to [Disabled] if above issues occur.

Intel Turbo Boost Technology

Intel Turbo Boost Technology enables the processor to run above its base operating fre-

quency when the operating system requests the highest performance state.

Enable Intel TXT Support

Use this to enable or disable Intel Trusted Execution Technology.

CPU Thermal Throttling

Enable CPU internal thermal control mechanisms to keep the CPU from overheating.

3.3.2 DRAM Configuration

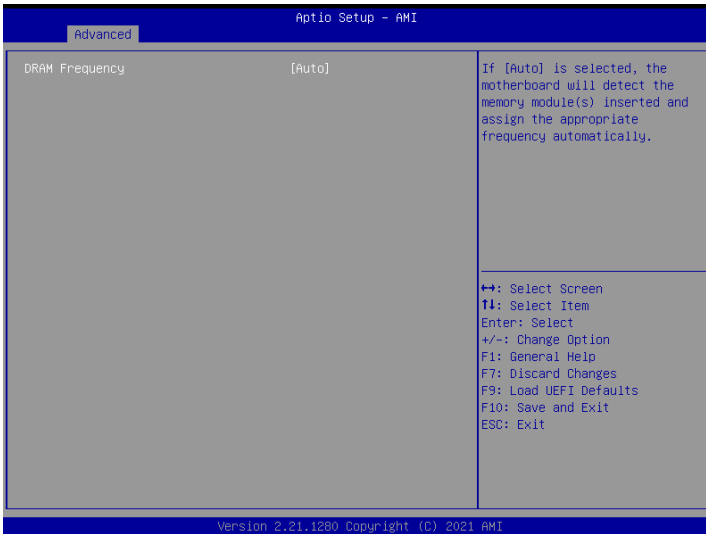

DRAM Frequency

If [Auto] is selected, the motherboard will detect the memory module(s) inserted and assign the appropriate frequency automatically.

3.3.3 Chipset Configuration

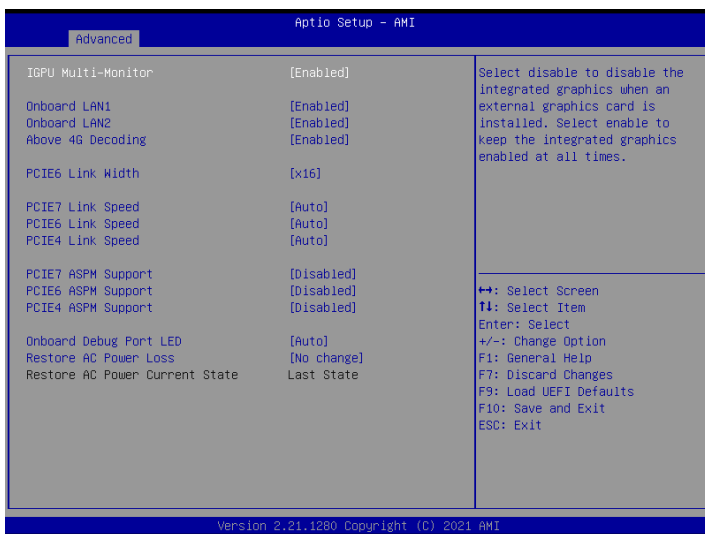

IGPU Multi-Monitor

Select Disable to disable the integrated graphics when an external graphics card is installed. Select Enable to keep the integrated graphics enabled at all times.

Onboard LAN1

Use this to enable or disable the Onboard LAN functions. The default value is [Enabled].

Onboard LAN2

Use this to enable or disable the Onboard LAN function. The default value is [Enabled].

Above 4G Decoding

Enable or disable above 4G MemoryMappedIO decoding. This item will be disabled automatically when Aperture Size is set to 2048MB.

PCIe6 Link Width

This allows you to select PCIe Link Width. The default value is [x16].

PCIe7 Link Speed

This allows you to select PCIe Link Speed. The default value is [Auto].

PCIe6 Link Speed

This allows you to select PCIe Link Speed. The default value is [Auto].

PCIe4 Link Speed

This allows you to select PCIe Link Speed. The default value is [Auto].

PCIe7 ASPM Support

This option enables or disables the ASPM support for all PCH downstream devices. The default value is [Disabled].

PCIe6 ASPM Support

This option enables or disables the ASPM support for all PCH downstream devices. The default value is [Disabled].

PCIe4 ASPM Support

This option enables or disables the ASPM support for all PCH downstream devices. The default value is [Disabled].

Onboard Debug Port LED

Enable or disable the onboard Dr. Debug LED.

Restore on AC/Power Loss

This allows you to set the power state after an unexpected AC/power loss. If [Power Off] is selected, the AC/power remains off when the power recovers. If [Power On] is selected, the AC/power resumes and the system starts to boot up when the power recovers. If [Last State] is selected, it will recover to the state before AC/power loss.

Restore AC Power Current State

This allows you to restore AC Power Current State.

3.3.4 Storage Configuration

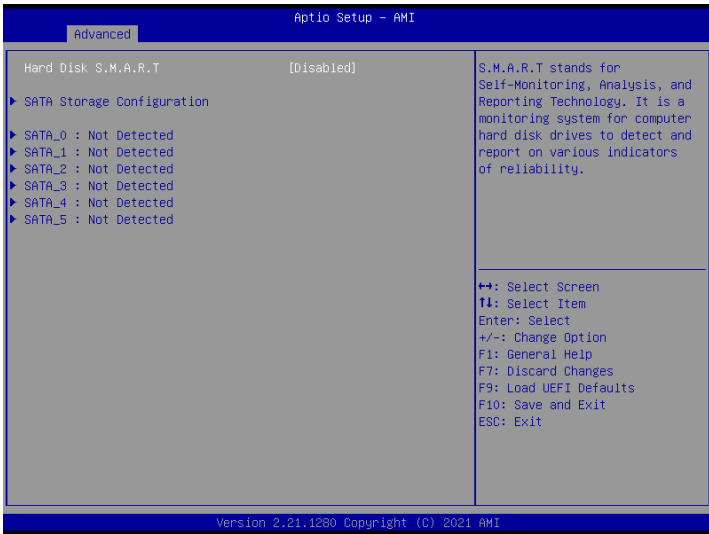

Hard Disk S.M.A.R.T.

S.M.A.R.T. stands for Self-Monitoring, Analysis, and Reporting Technology. It is a monitoring system for computer hard disk drives to detect and report on various indicators or reliability.

SATA Storage Configuration

SATA Controller

Use this item to enable or disable SATA Controllers.

SATA/M.2_SATA Mode Selection

Identify the SATA/M.2_SATA port is connected to Solid State Drive or Hard Disk Drive. Press <Ctrl+I> to enter RAID ROM during UEFI POST process.

Support Aggressive Link Power Management

Use this item to enable or disable SALP.

3.3.5 NVMe Configuration

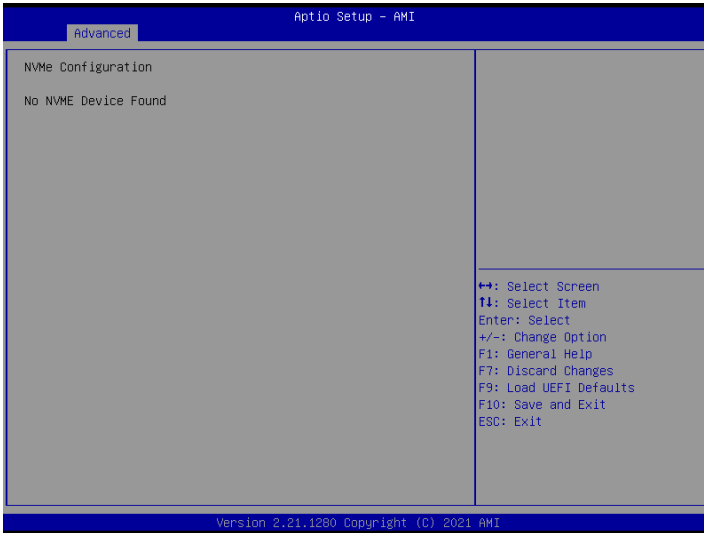

The NVMe Configuration displays the NVMe controller and Drive information.

3.3.6 ACPI Configuration



PCIE Devices Power On

This allows the system to be waked up by a PCIE device and enable wake-on-LAN.

Ring-In Power On

This allows the system to be waked up by onboard COM port modem Ring-In signals.

RTC Alarm Power On

This allows the system to be waked up by the real time clock alarm. Set it to By OS to let it be handled by your operating system.

3.3.7 Super IO Configuration

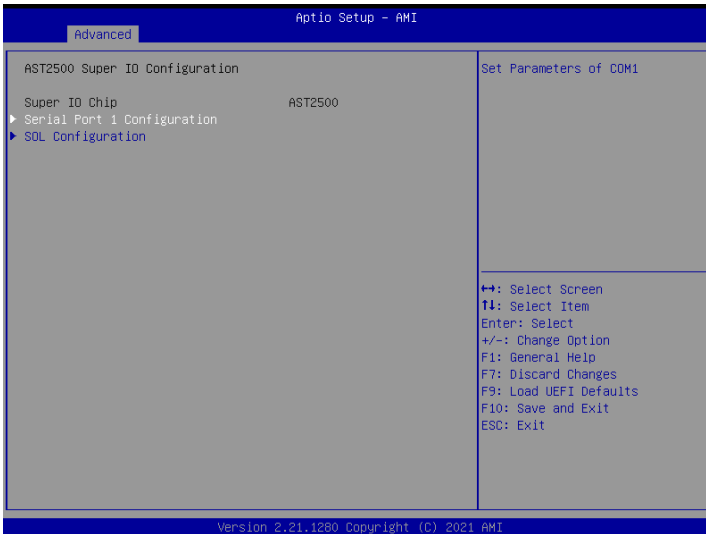

Serial Port 1 Configuration

Use this item to set parameters of Serial Port 1 (COM1).

Serial Port

Use this item to enable or disable the serial port.

Change Settings

Use this item to select an optimal setting for Super IO device.

SOL Configuration

Use this item to set SOL configuration.

SOL Port

Use this item to enable or disable the SOL port.

Change Settings

Use this item to select an optimal setting for Super IO device.

3.3.8 Serial Port Console Redirection

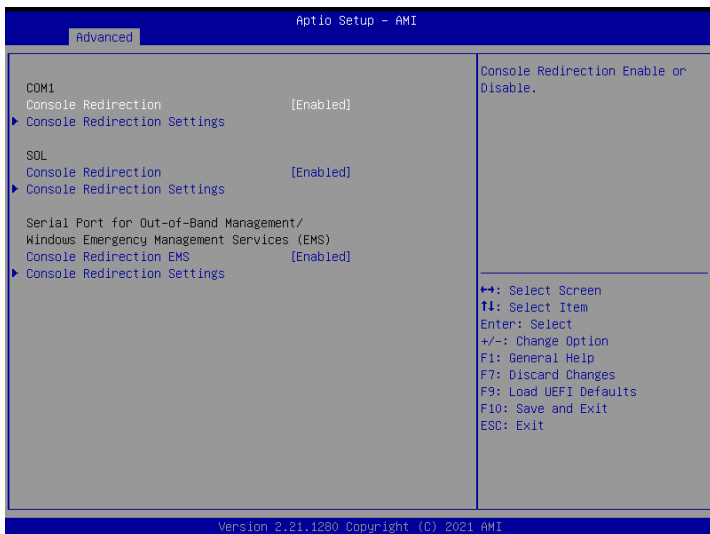

COM1 / SOL

Console Redirection

Use this option to enable or disable Console Redirection. If this item is set to Enabled, you can select a COM Port to be used for Console Redirection.

Console Redirection Settings

Use this option to configure Console Redirection Settings, and specify how your computer and the host computer to which you are connected exchange information.

Terminal Type

Use this item to select the preferred terminal emulation type for out-of-band management. It is recommended to select [VT-UTF8].

| Option | Description |
|---------|---|
| VT100 | ASCII character set |
| VT100+ | Extended VT100 that supports color and function keys |
| VT-UTF8 | UTF8 encoding is used to map Unicode chars onto 1 or more bytes |
| ANSI | Extended ASCII character set |

Bits Per Second

Use this item to select the serial port transmission speed. The speed used in the host computer and the client computer must be the same. Long or noisy lines may require lower transmission speed. The options include [9600], [19200], [57600] and [115200].

Data Bits

Use this item to set the data transmission size. The options include [7] and [8] (Bits).

Parity

Use this item to select the parity bit. The options include [None], [Even], [Odd], [Mark] and [Space].

Stop Bits

The item indicates the end of a serial data packet. The standard setting is [1] Stop Bit. Select [2] Stop Bits for slower devices.

Flow Control

Use this item to set the flow control to prevent data loss from buffer overflow. When sending data, if the receiving buffers are full, a "stop" signal can be sent to stop the data flow. Once the buffers are empty, a "start" signal can be sent to restart the flow. Hardware flow uses two wires to send start/stop signals. The options include [None] and [Hardware RTS/CTS].

VT-UTF8 Combo Key Support

Use this item to enable or disable the VT-UTF8 Combo Key Support for ANSI/VT100 terminals.

Recorder Mode

Use this item to enable or disable Recorder Mode to capture terminal data and send it as text messages.

Resolution 100x31

Use this item to enable or disable extended terminal resolution support.

Putty Keypad

Use this item to select Function Key and Keypad on Putty.

Legacy Console Redirection**Legacy Console Redirection Settings**

Use this option to configure Legacy Console Redirection Settings, and specify how your computer and the host computer to which you are connected exchange information.

Redirection COM Port

Select a COM port to display redirection of Legacy OS and Legacy OPROM Messages.

Resolution

On Legacy OS, the Number of Rows and Columns supported redirection.

Redirect After POST

When Bootloader is selected, then Legacy Console Redirection is disabled before booting to legacy OS. When Always Enable is selected, then Legacy Console Redirection is enabled for legacy OS. Default setting for this option is set to Always Enable.

Serial Port for Out-of-Band Management/Windows Emergency Management Services (EMS)

Console Redirection EMS

Use this option to enable or disable Console Redirection. If this item is set to Enabled, you can select a COM Port to be used for Console Redirection.

Console Redirection Settings

Use this option to configure Console Redirection Settings, and specify how your computer and the host computer to which you are connected exchange information.

Out-of-Band Mgmt Port

Microsoft Windows Emergency Management Services (EMS) allows for remote management of a Windows Server OS through a serial port.

Terminal Type EMS

Use this item to select the preferred terminal emulation type for out-of-band management. It is recommended to select [VT-UTF8].

| Option | Description |
|---------|---|
| VT100 | ASCII character set |
| VT100+ | Extended VT100 that supports color and function keys |
| VT-UTF8 | UTF8 encoding is used to map Unicode chars onto 1 or more bytes |
| ANSI | Extended ASCII character set |

Bits Per Second EMS

Use this item to select the serial port transmission speed. The speed used in the host computer and the client computer must be the same. Long or noisy lines may require lower transmission speed. The options include [9600], [19200], [57600] and [115200].

Flow Control EMS

Use this item to set the flow control to prevent data loss from buffer overflow. When sending data, if the receiving buffers are full, a "stop" signal can be sent to stop the data flow. Once the buffers are empty, a "start" signal can be sent to restart the flow. Hardware flow uses two wires to send start/stop signals. The options include [None], [Hardware RTS/CTS], and [Software Xon/Xoff].

Data Bits EMS

Parity EMS

Stop Bits EMS

3.3.9 H/W Monitor

In this section, it allows you to monitor the status of the hardware on your system, including the parameters of the CPU temperature, motherboard temperature, CPU fan speed, chassis fan speed, and the critical voltage.

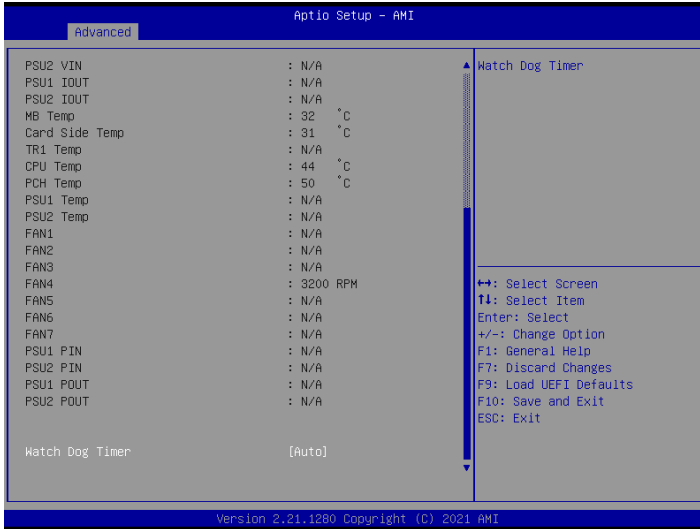

Watch Dog Timer

This allows you to enable or disable the Watch Dog Timer. The default value is [Disabled].

3.3.10 Intel SPS Configuration

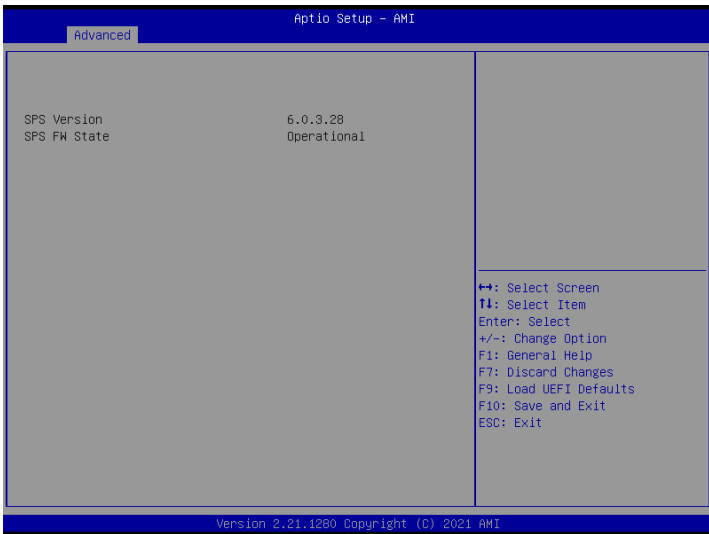

SPS screen displays the Intel SPS Configuration information, such as Operational Firmware Version and Firmware State.

3.3.11 Driver Health

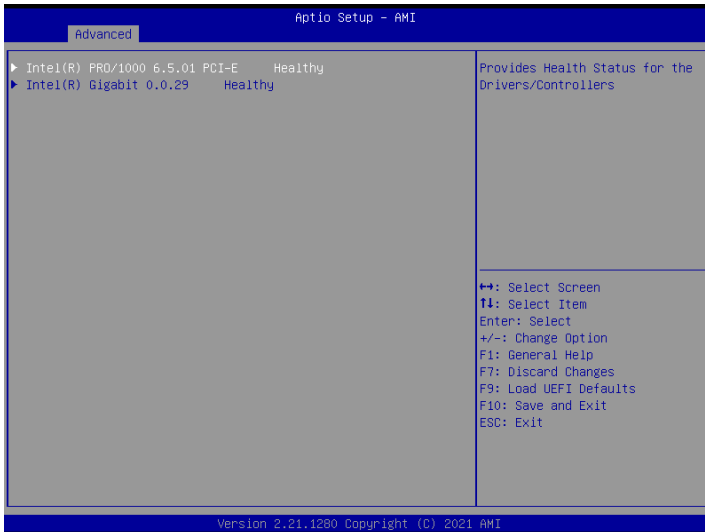

Intel(R) PRO/1000 6.5.01 PCI-E Healthy

This provides health status for the drivers/controllers.

Intel(R) Gigabit 0.0.29 Healthy

This provides health status for the drivers/controllers.

Network Stack

Use this item to enable or disable UEFI Network Stack.

Ipv4 PXE Support

Use this item to enable or disable IPv4 PXE boot support. If disabled, IPv4 PXE boot support will not be available.

Ipv4 HTTP Support

Use this item to enable or disable IPv4 HTTP boot support. If disabled, IPv4 HTTP boot support will not be available.

Ipv6 PXE Support

Use this item to enable or disable IPv6 PXE boot support. If disabled, IPv6 PXE boot support will not be available.

IPv6 HTTP Support

Use this item to enable or disable IPv6 HTTP boot support. If disabled, IPv6 HTTP boot support will not be available.

PXE boot wait time

Wait time in seconds to press ESC key to abort the PXE boot. Use either +/- or numeric keys to set the value.

Media detect count

Number of times the presence of media will be checked. Use either +/- or numeric keys to set the value.

Endless UEFI PXE Boot Support

Use this item to enable or disable Endless boot for UEFI PXE Boot, retry each port in infinite loop.

3.3.12 Tls Auth Configuration

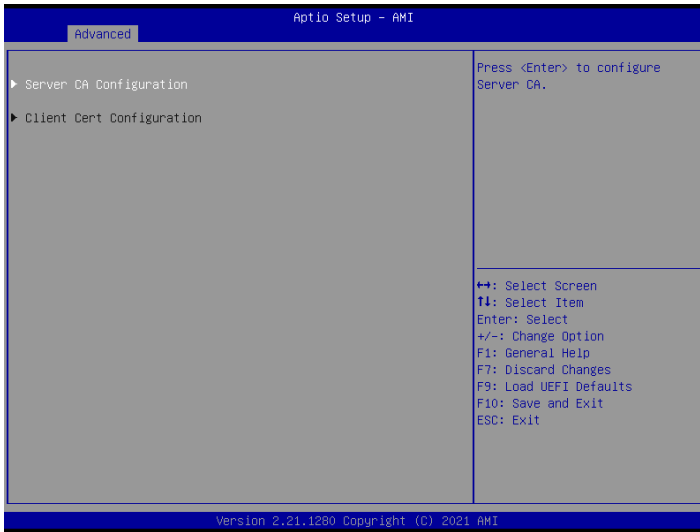

Server CA Configuration

Press <Enter> to configure Server CA.

Client Cert Configuration

Press <Enter> to configure Client Cert.

3.3.13 RAM Disk Configuration

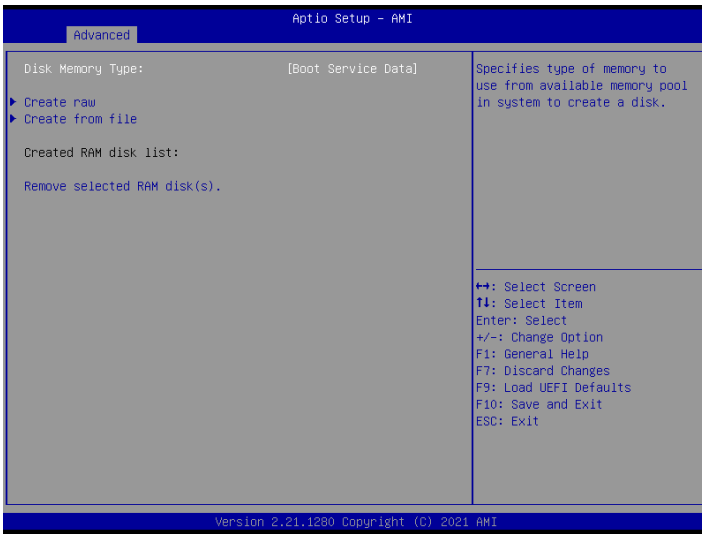

Disk Memory Type

Specifies type of memory to use from available memory pool in system to create a disk.

Create raw

Create a raw RAM disk.

Create from file

Create a RAM disk from a given file.

Remove selected RAM disk(s).

Remove selected RAM disk(s)

3.3.14 iSCSI Configuration

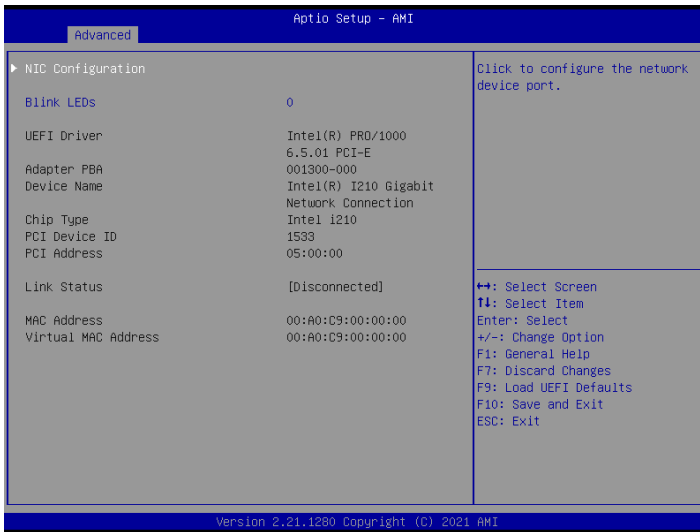

Attempt Priority

Change this priority using +/- keys. Use arrow keys to select the attempt then press +/- to move the attempt up/down in the attempt order list.

Host iSCSI Configuration

Use this to configure iSCSI settings.

3.3.15 Instant Flash

Instant Flash is a UEFI flash utility embedded in Flash ROM. This convenient UEFI update tool allows you to update system UEFI without entering operating systems first like MS-DOS or Windows. Just save the new UEFI file to your USB flash drive, floppy disk or hard drive and launch this tool, then you can update your UEFI only in a few clicks without preparing an additional floppy diskette or other complicated flash utility. Please be noted that the USB flash drive or hard drive must use FAT32/16/12 file system. If you execute Instant Flash utility, the utility will show the UEFI files and their respective information. Select the proper UEFI file to update your UEFI, and reboot your system after the UEFI update process is completed.

3.4 Server Mgmt

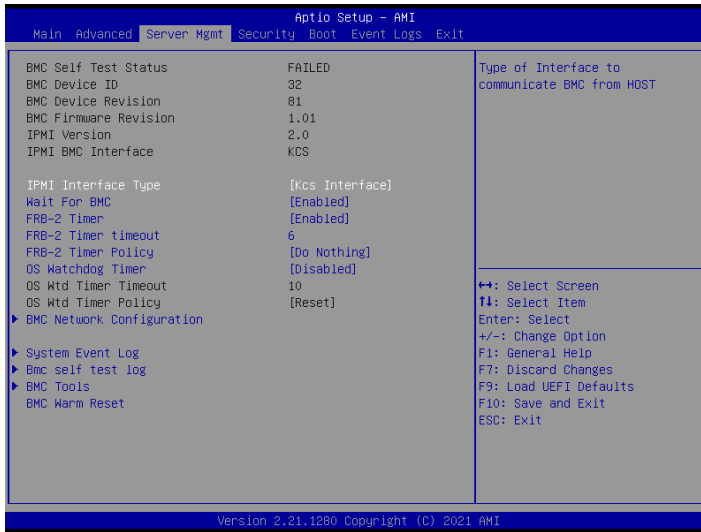

IPMI Interface Type

Use this item to configure the type of interface to communicate BMC from HOST.

Wait For BMC

Wait For BMC response for specified time out. BMC starts at the same time when BIOS starts during AC power ON. It takes around 90 seconds to initialize Host to BMC interfaces.

FRB-2 Timer

Use this item to enable or disable FRB-2 timer (POST timer).

FRB-2 Timer Timeout

Enter value between 1 to 30 min for FRB-2 Timer Expiration.

FRB-2 Timer Policy

Use this item to configure how the system should respond if the FRB-2 Timer expires. Not available if FRB-2 Timer is disabled.

OS Watchdog Timer

If enabled, starts a BIOS timer which can only be shut off by Management Software after the OS loads. Helps determine that the OS successfully loaded or follows the OS Boot Watchdog Timer policy.

3.4.1 BMC Network Configuration



BMC Out of band Access

Use this item to enable or disable BMC Out of band Access.

Manual Setting IPMI LAN

If [No] is selected, the IP address is assigned by DHCP. If you prefer using a static IP address, toggle to [Yes], and the changes take effect after the system reboots. The default value is [No].

Configuration Address Source

Select to configure BMC network parameters statically or dynamically (by BIOS or BMC). Configuration options: [Static] and [DHCP].

Static: Manually enter the IP Address, Subnet Mask and Gateway Address in the BIOS for BMC LAN channel configuration.

DHCP: IP address, Subnet Mask and Gateway Address are automatically assigned by the network's DHCP server.



When [DHCP] or [Static] is selected, do NOT modify the BMC network settings on the IPMI web page.



The default login information for the IPMI web interface is:

Username: admin

Password: admin

For more instructions on how to set up remote control environment and use the IPMI management platform, please refer to the IPMI Configuration User Guide or go to the Support website at: <http://www.asrockrack.com/support/faq.asp>

VLAN

Enabled/Disabled Virtual Local Area Network.

If [Enabled] is selected, configure the items below.

IPV6 Support

Enabled/Disable LAN1 IPV6 Support.

Manual Setting IPMI LAN(IPV6)

Select to configure LAN channel parameters statically or dynamically(by BIOS or BMC).

Unspecified option will not modify any BMC network parameters during BIOS phase.

IPV6 Index

IPV6 Index - Set Selector for Static IP, range 0 to 15.

3.4.2 System Event Log

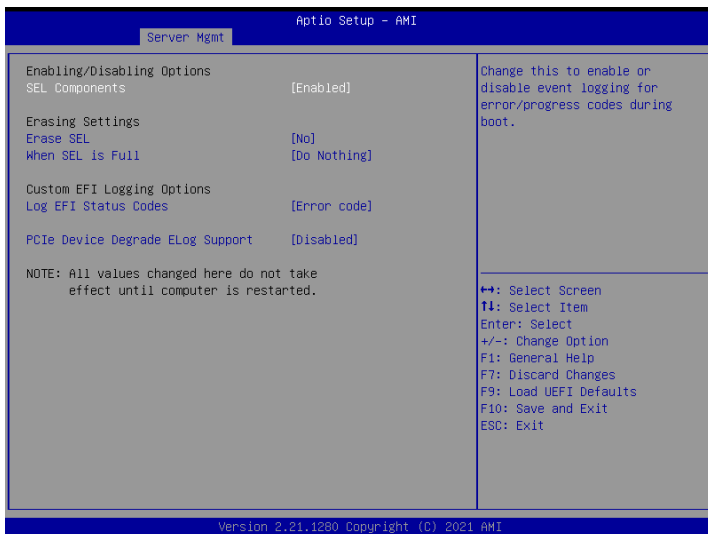

SEL Components

Change this to enable or disable event logging for error/progress codes during boot.

Erase SEL

Use this to choose options for erasing SEL.

When SEL is Full

Use this to choose options for reactions to a full SEL.

Log EFI Status Codes

Use this item to disable the logging of EFI Status Codes or log only error code or only progress code or both.

PCIe Device Degrade ELog Support

Use this item to enable or disable PCIe Device Degrade Error Logging Support.

3.4.3 Bmc self test log

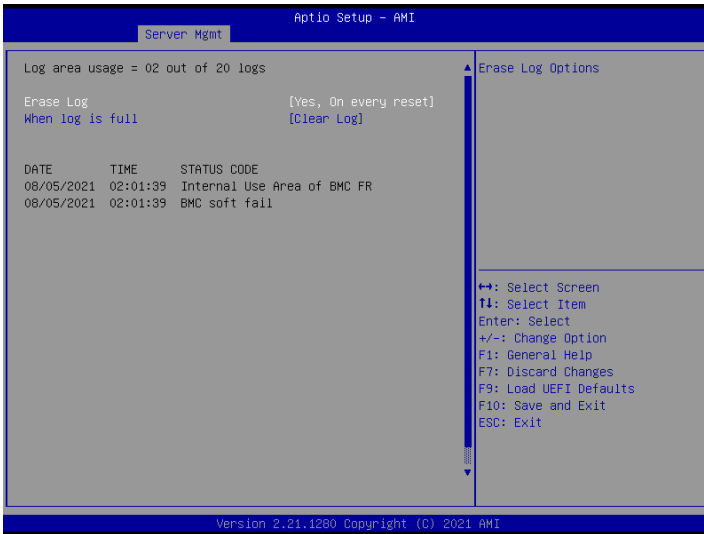

Erase Log

Use this to choose options for erasing Log.

When Log is Full

Use this to select the action to be taken when log is full.

3.4.4 BMC Tools



Load BMC Default Settings

Use this item to Load BMC Default Settings

KCS Control

Select this KCS interface state after POST end. If [Enabled] is selected, the BMC will remain KCS interface after POST stage. If [Disabled] is selected, the BMC will disable KCS interface after POST stage

BMC Warm Reset

Press <Enter> to do BMC Warm Reset.

3.5 Security

In this section, you may set or change the supervisor/user password for the system. For the user password, you may also clear it.

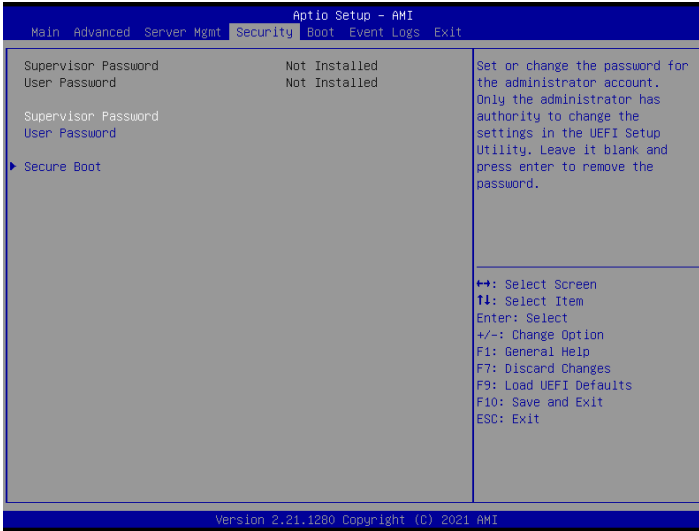

Supervisor Password

Set or change the password for the administrator account. Only the administrator has authority to change the settings in the UEFI Setup Utility. Leave it blank and press enter to remove the password.

User Password

Set or change the password for the user account. Users are unable to change the settings in the UEFI Setup Utility. Leave it blank and press enter to remove the password.

Secure Boot

Use this to enable or disable Secure Boot Control. The default value is [Disabled]. Enable to support Windows Server 2012 R2 or later versions Secure Boot.

Secure Boot Mode

Secure Boot mode selector: Standard/Custom. In Custom mode, Secure Boot Policy variables can be configured by a physically present user without full authentication.

3.5.1 Key Management

In this section, expert users can modify Secure Boot Policy variables without full authentication.

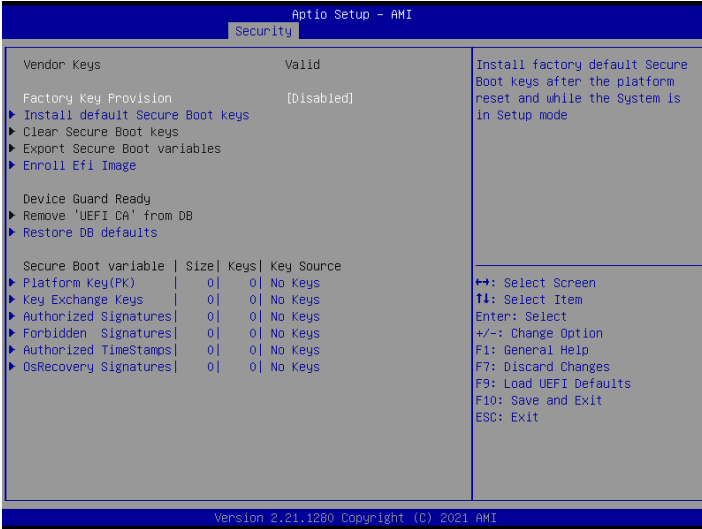

Factory Key Provision

Install factory default Secure Boot keys after the platform reset and while the System is in Setup mode.

Clear Secure Boot keys

Force System to Setup Mode - clear all Secure Boot Variables. Change takes effect after reboot.

Export Secure Boot variables

Copy NVRAM content of Secure Boot variables to files in a root folder on a file system device.

Enroll Efi Image

Allow the image to run in Secure Boot mode. Enroll SHA256 Hash certificate of a PE image into Authorized Signature Database (db).

Remove 'UEFI CA' from DB

Device Guard ready system must not list 'Microsoft UEFI CA' Certificate in Autho

rized Signature database (db).

Restore DB defaults

Restore DB variable to factory defaults.

Platform Key(PK)

Enroll Factory Defaults or load certificates from a file:

1. Public Key Certificate in:

- a) EFI_SIGNATURE_LIST
- b) EFI_CERT_X509 (DER)
- c) EFI_CERT_RSA2048 (bin)
- d) EFI_CERT_SHA256, 384, 512

2. Authenticated UEFI Variable

3. EFI PE/COFF Image(SHA256)

Key Source: Factory, External, Mixed

Key Exchange Keys

Enroll Factory Defaults or load certificates from a file:

1. Public Key Certificate in:

- a) EFI_SIGNATURE_LIST
- b) EFI_CERT_X509 (DER encoded)
- c) EFI_CERT_RSA2048 (bin)
- d) EFI_CERT_SHA256, 384, 512

2. Authenticated UEFI Variable

3. EFI PE/COFF Image(SHA256)

Key Source: Factory, External, Mixed

Authorized Signatures

Enroll Factory Defaults or load certificates from a file:

1. Public Key Certificate in:

- a) EFI_SIGNATURE_LIST

b) EFI_CERT_X509 (DER encoded)

c) EFI_CERT_RSA2048 (bin)

d) EFI_CERT_SHA256, 384, 512

2. Authenticated UEFI Variable

3. EFI PE/COFF Image(SHA256)

Key Source: Factory, External, Mixed

Forbidden Signatures

Enroll Factory Defaults or load certificates from a file:

1. Public Key Certificate in:

a) EFI_SIGNATURE_LIST

b) EFI_CERT_X509 (DER encoded)

c) EFI_CERT_RSA2048 (bin)

d) EFI_CERT_SHA256, 384, 512

2. Authenticated UEFI Variable

3. EFI PE/COFF Image(SHA256)

Key Source: Factory, External, Mixed

Authorized TimeStamps

Enroll Factory Defaults or load certificates from a file:

1. Public Key Certificate in:

a) EFI_SIGNATURE_LIST

b) EFI_CERT_X509 (DER encoded)

c) EFI_CERT_RSA2048 (bin)

d) EFI_CERT_SHA256, 384, 512

2. Authenticated UEFI Variable

3. EFI PE/COFF Image(SHA256)

Key Source: Factory, External, Mixed

OsRecovery Signatures

Enroll Factory Defaults or load certificates from a file:

1. Public Key Certificate in:

- a) EFI_SIGNATURE_LIST
- b) EFI_CERT_X509 (DER encoded)
- c) EFI_CERT_RSA2048 (bin)
- d) EFI_CERT_SHA256, 384, 512

2. Authenticated UEFI Variable

3. EFI PE/COFF Image(SHA256)

Key Source: Default, External, Mixed, Test

3.6 Boot Screen

In this section, it will display the available devices on your system for you to configure the boot settings and the boot priority.



Boot Option #1

Use this item to set the system boot order.

Boot Option #2

Use this item to set the system boot order.

Boot Option #3

Use this item to set the system boot order.

Boot Option #4

Use this item to set the system boot order.

Boot Option #5

Use this item to set the system boot order.

Boot Option #6

Use this item to set the system boot order.

Setup Prompt Timeout

This shows the number of seconds to wait for setup activation key. 65535(0XFFFF) means indefinite waiting.

Bootup Num-Lock

If this item is set to [On], it will automatically activate the Numeric Lock function after boot-up.

Boot Beep

Select whether the Boot Beep should be turned on or off when the system boots up. Please note that a buzzer is needed.

Full Screen Logo

Use this item to enable or disable OEM Logo. The default value is [Enabled].

3.7 Event Logs

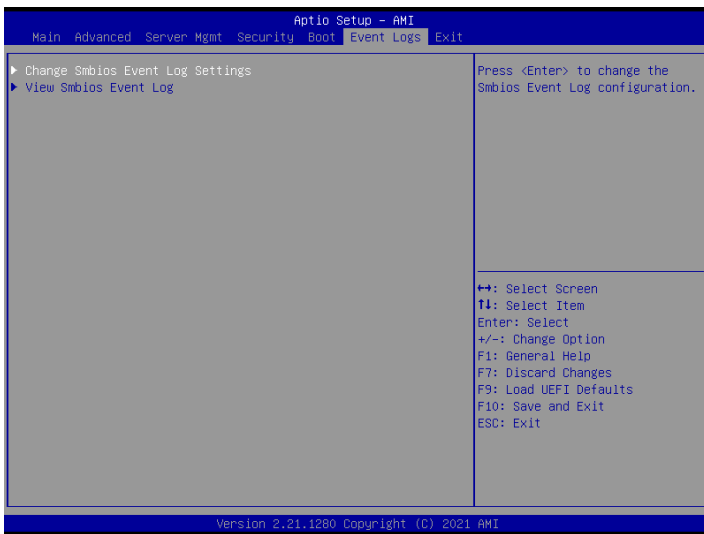

Change Smbios Event Log Settings

This allows you to configure the Smbios Event Log Settings.

When entering the item, you will see the followings:

Smbios Event Log

Use this item to enable or disable all features of the SMBIOS Event Logging during system boot.

Erase Event Log

The options include [No], [Yes, Next reset] and [Yes, Every reset]. If Yes is selected, all logged events will be erased.

When Log is Full

Use this item to choose options for reactions to a full Smbios Event Log. The options include [Do Nothing] and [Erase Immediately].

Log System Boot Event

Choose option to enable/disable logging of System boot event.

View Smbios Event Log

Press <Enter> to view the Smbios Event Log records.



All values changed here do not take effect until computer is restarted.

3.8 Exit Screen

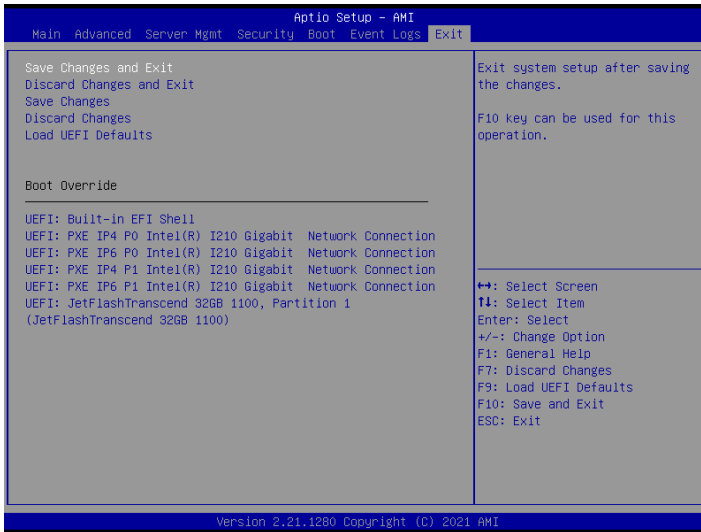

Save Changes and Exit

When you select this option, the following message “Save configuration changes and exit setup?” will pop-out. Press <F10> key or select [Yes] to save the changes and exit the UEFI SETUP UTILITY.

Discard Changes and Exit

When you select this option, the following message “Discard changes and exit setup?” will pop-out. Press <ESC> key or select [Yes] to exit the UEFI SETUP UTILITY without saving any changes.

Save Changes

When you select this option, the following message “Save changes?” will pop-out. Press <F7> key or select [Yes] to save all changes.

Discard Changes

When you select this option, the following message “Discard changes?” will pop-out. Press <F7> key or select [Yes] to discard all changes.

Load UEFI Defaults

Load UEFI default values for all the setup questions. F9 key can be used for this operation.

Boot Override

These items displays the available devices. Select an item to start booting from the selected device.

Chapter 4 Software Support

4.1 Install Operating System

This motherboard supports various Microsoft® Windows® / Linux compliant. Because motherboard settings and hardware options vary, use the setup procedures in this chapter for general reference only. Refer to your OS documentation for more information.

**Please download the Intel® SATA Floppy Image driver from the ASRock Rack's website (www.asrockrack.com) to your USB drive or simply install the SATA driver from the Support CD while installing OS in SATA RAID mode.*

4.2 Support CD Information

The Support CD that came with the motherboard contains necessary drivers and useful utilities that enhance the motherboard's features.

4.2.1 Running The Support CD

To begin using the support CD, insert the CD into your CD-ROM drive. The CD automatically displays the Main Menu if "AUTORUN" is enabled in your computer. If the Main Menu does not appear automatically, locate and double click on the file "ASRSetup.exe" from the root folder in the Support CD to display the menu.

4.2.2 Drivers Menu

The Drivers Menu shows the available device's drivers if the system detects installed devices. Please install the necessary drivers to activate the devices.

4.2.3 Utilities Menu

The Utilities Menu shows the application softwares that the motherboard supports. Click on a specific item then follow the installation wizard to install it.

4.2.4 Contact Information

If you need to contact ASRock Rack or want to know more about ASRock Rack, welcome to visit ASRock Rack's website at <http://www.ASRockRack.com>; or you may contact your dealer for further information.

Chapter 5 Troubleshooting

5.1 Troubleshooting Procedures

Follow the procedures below to troubleshoot your system.



Always unplug the power cord before adding, removing or changing any hardware components. Failure to do so may cause physical injuries to you and damages to motherboard components.

1. Disconnect the power cable and check whether the PWR LED is off.
2. Unplug all cables, connectors and remove all add-on cards from the motherboard.
Make sure that the jumpers are set to default settings.
3. Confirm that there are no short circuits between the motherboard and the chassis.
4. Install a CPU and fan on the motherboard, then connect the chassis speaker and power LED.

If there is no power...

1. Confirm that there are no short circuits between the motherboard and the chassis.
2. Make sure that the jumpers are set to default settings.
3. Check the settings of the 115V/230V switch on the power supply.
4. Verify if the battery on the motherboard provides ~3VDC. Install a new battery if it does not.

If there is no video...

1. Try replugging the monitor cables and power cord.
2. Check for memory errors.

If there are memory errors...

1. Verify that the DIMM modules are properly seated in the slots.
2. Use recommended DDR4 ECC UDIMMs.
3. If you have installed more than one DIMM modules, they should be identical with the same brand, speed, size and chip-type.
4. Try inserting different DIMM modules into different slots to identify faulty ones.
5. Check the settings of the 115V/230V switch on the power supply.

Unable to save system setup configurations...

1. Verify if the battery on the motherboard provides ~3VDC. Install a new battery if it does not.
2. Confirm whether your power supply provides adequate and stable power.

Other problems...

1. Try searching keywords related to your problem on ASRock Rack's FAQ page:
<http://www.asrockrack.com/support>

5.2 Technical Support Procedures

If you have tried the troubleshooting procedures mentioned above and the problems are still unsolved, please contact ASRock Rack's technical support with the following information:

1. Your contact information
2. Model name, BIOS version and problem type.
3. System configuration.
4. Problem description.

You may contact ASRock Rack's technical support at:

<http://www.asrockrack.com/support/tsd.asp>

5.3 Returning Merchandise for Service

For warranty service, the receipt or a copy of your invoice marked with the date of purchase is required. By calling your vendor or going to our RMA website (<http://event.asrockrack.com/tsd.asp>) you may obtain a Returned Merchandise Authorization (RMA) number.

The RMA number should be displayed on the outside of the shipping carton which is mailed prepaid or hand-carried when you return the motherboard to the manufacturer. Shipping and handling charges will be applied for all orders that must be mailed when service is complete.

This warranty does not cover damages incurred in shipping or from failure due to alteration, misuse, abuse or improper maintenance of products.

Contact your distributor first for any product related problems during the warranty period.

Contact Information

If you need to contact ASRock Rack or want to know more about ASRock Rack, you're welcome to visit ASRock Rack's website at <http://www.asrockrack.com>; or you may contact your dealer for further information. For technical questions, please submit a support request form at <https://event.asrockrack.com/tsd.asp>

ASRock Rack Incorporation

e-mail: ASRockRack_sales@asrockrack.com

ASRock Rack EUROPE B.V.

Bijsterhuizen 11-11

6546 AR Nijmegen

The Netherlands

Phone: +31-24-345-44-33

ASRock Rack America, Inc.

13848 Magnolia Ave, Chino, CA91710 U.S.A.

Phone: +1-909-590-8308

Fax: +1-909-590-1026